

## Investigating the Performance of the 3-Phase Induction Machine

\*Hani Y. Alfahed and \*\*Khaled S.Alrasheed

\*Eng.,PAAET,Kuwait

\*\*Eng.,PAAET,Kuwait

Corresponding Author: Hani Y.Alfahed

### ABSTRACT

*This paper investigates the performance of the 3-phase induction machine under several operating conditions through several laboratory experiments. The load characteristics of the induction machine in motoring and generating mode for both star and delta connections were investigated, then compared in the discussion. In addition, the star up transient current for delta connection was examined and discussed. Moreover, reactive power compensation and power factor improvement were all achieved by adding a 3-phase capacitor bank to the 3-phase induction machine. Finally, the results in this paper were generated practically and recorded in the results section with brief description for each milestone, and then they analyzed in detail in the discussion section.*

**KEYWORDS:** Induction machine, synchronous speed, slip, startup transient current and power factor improvement.

Date of Submission: 25-12-2019

Date of Acceptance: 03-01-2020

### I. INTRODUCTION

The aim of the paper is firstly, to determine the loading characteristics of the 3-phase induction machine when running as a motor and as a generator for both star and delta connections, secondly, to examine its startup transient current when connected in delta, and finally to show the effect on the power factor when adding a 3-phase capacitor bank to the 3-phase induction machine.

#### 1.1 Three phase induction machine

The 3-phase induction machines are commonly used as motors and they are the most widely used motors in the industrial field due to their simplicity, low cost, easy maintenance and hardness. Basically, they run almost at constant speed from no load to full load where they are applicable to drive large fans and pumps in the power stations [1]. There are two types: (a) squirrel phase induction machine and (b) wound rotor induction machine. The stator for each machine is the same. It consists of stacked laminations that form the cylindrical core where these laminations are punched to allow windings to fit inside the slots. In addition, the laminations are enclosed inside a hollow steel frame. Fig.1 illustrates the construction of a real stator of induction machine and its schematic diagram [1].



Fig.1 (a) A stator of induction machines showing its windings. Adapted from <https://www.bodine-electric.com>

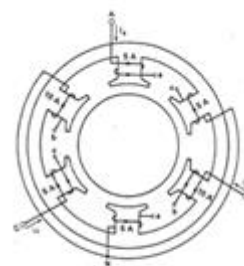
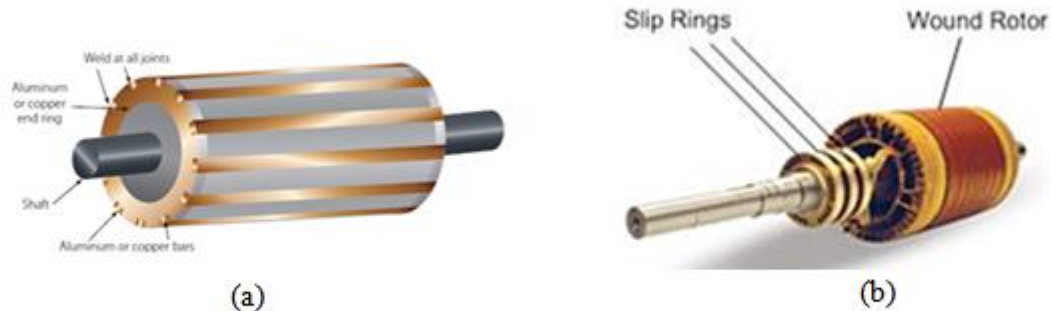

Fig.1 (b) A schematic diagram of a 6-pole stator and its windings[1]

However, the construction of rotor determines the type of three phase machine. The rotor of the squirrel cage motor composed of copper bars inserted inside the slots of the core of the rotor where they are welded at each end of the rotor with copper end ring as shown in Fig.2(a), whereas that of wound induction machine composed of three phase winding enclosed in the slots of the rotor, where the end of the rotor is attached to



**Fig.2 Rotor for 3-phase induction motor. (a) squirrel cage rotor (b) wound rotor.**  
Adapted from "<http://www.avstop.com>"

three slip rings as shown in Fig.2(b). Those slip ring enable the induction machine to connect its rotor to an external circuit such as a rheostat to control the speed of the motor which is impossible to connect it in the case of a squirrel cage rotor [1].

**1.2 Principle of operation**

In order for the induction machine to run as a motor, three phase currents, where each one is equal in magnitude and displaced 120° from each other, must be fed to its 3-phase stator windings. Based on these arrangements, a revolving magnetic field will be established in the air gap between the rotor and the stator which will cut the rotor and induces a voltage across its windings according the following equation:

$$V_{induced} = 4.44 f N \phi_{max} \quad (1) \quad [1]$$

If the rotor is short circuited-as in the case of squirrel cage rotor, currents will flow in its windings and consequently a torque will be created causing the rotor to rotate in the direction of the magnetic field according to the following formulas [1]:

$$I_2 = \frac{V_2}{Z_2} = \frac{sE_2}{\sqrt{R_2^2 + s^2X_2^2}} \quad (2) \quad [6]$$

$$T = 3 \frac{1}{\omega_s} \frac{sE_2^2 R_2}{R_2^2 + s^2X_2^2} \quad (3) \quad [6]$$

**1.3 Slip in the induction motor**

In order for the motor to run, there must be a difference between the speed of the magnetic field (or the synchronous speed) and the speed of the rotor which called the slip so that the flux will cut the rotor to induce a voltage across its terminals. The slip can be calculated according to the formula:

$$S = \frac{N_s - N_R}{N_s} \quad (4)$$

And the synchronous speed is determined by number of poles in the stator of the machine and the frequency fed into its stator according to the formula:

$$N_s = \frac{120f}{p} \quad (5)$$

So by varying the rotor speed while keeping the synchronous speed constant, we can obtain different values for the slip. So, for:

- (a)  $N_R = 0$ , the slip will be equal to 1. (Locked rotor mode)
- (b)  $N_R > 0$  and  $N_S > 0$ , the slip will be between 0 and 1 (motor mode)
- (c)  $N_R < 0$  and  $N_S > 0$ , the slip will be greater than 1 (generator mode) [1]

Unlike the synchronous machine circuit analysis, both the stator circuit and the rotor circuit should be analyzed together. Fig.3 shows the circuit diagram of the induction motor where  $R_1$  and  $X_1$  represent the stator resistance and reactance, respectively, and  $R_2$  and  $sX_2$  represent the rotor resistance and a reactance. In addition, the core reactance and resistance (not shown) are usually included in the calculation of the induction machine circuit analysis [6].

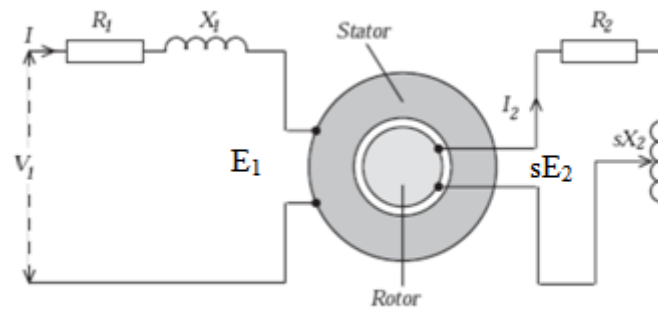

Fig.3 Wound rotor for induction circuit diagram [6]

**1.4 Starting current for induction machine**

Transient characteristics are usually studied along with load characteristics for any motor in order to have a proper running and starting operations. In the 3-phase induction motor, the starting current is usually 3 to 4 times the full load current. Fig.4 shows the torque speed characteristics in 3 different modes; motor mode, generating mode and braking mode.

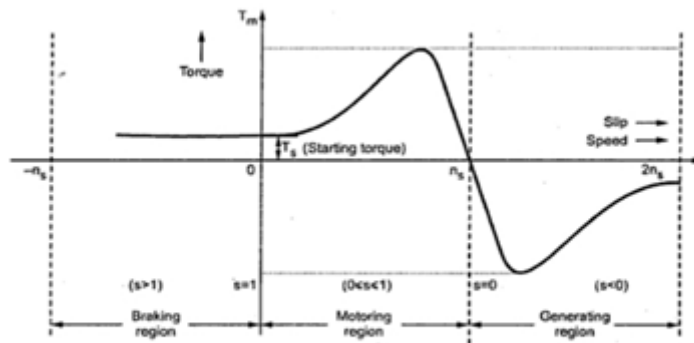

Fig.4 Torque speed characteristics for 3-phase induction machine. Adapted from "https://www.bing.com"

**II. METHODOLOGY AND RESULTS**

The upcoming experiments were performed using the equipment manufactured from German company called Lucas-Nulle. The specifications of the induction machine can be found in table 13 in appendix 1.

**2.1 Milestone 1 (Star connection)**

The stator of the induction machine can be connected in star or delta. In this part of the experiment, the three windings of the stator were connected in star connection. Fig.5 illustrates the schematic diagram of 3-phase supply feeding the star connected induction machine through 4-pole output switch. A voltmeter was connected across one of the phases, while an ammeter was used to measure the drawn line current. In addition, the machine was coupled in the laboratory to a load machine used as brake to make the induction machine operating in motoring mode. Moreover, the load machine was used as a servo motor (prime mover) to make the induction machine running in generating mode.

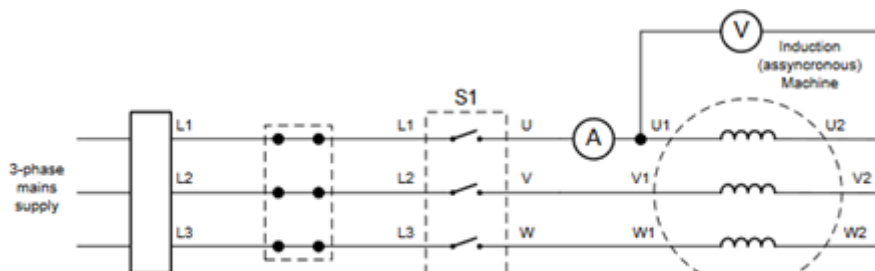

Fig.5 Schematic diagram of star connected induction machine [7]

**2.1.1 Step 1 and 2 (Line start of induction machine)**

The load machine was set to motoring mode to run the machine as a motor, and loading torque was adjusted to zero. The 3-phase supply was switched on and the machine was accelerating until it settled down to rotor speed slightly less than the synchronous speed. Table 1 summarizes the results.

**Table 1 : Rotor speed, synchronous speed and the slip**

Rotor speed (measured )	Synchronous speed (Calculated) $N_s = 120 * \frac{f}{p}$	Slip $S = \frac{N_s - N_R}{N_s}$
2940 rpm	$N_s = 120 * \frac{50}{2} = 3000$ rpm	$S = \frac{(3000 - 2940)}{3000} = 0.02$

**2.1.2 Step 3 (Identifying the direction of operation for induction machine)**

When the load machine was adjusted to speed control mode, and by adding a positive torque, the speed was decreasing and rotating in clockwise direction (1st quadrant). On the other hand, when a negative torque added, the speed was increasing and rotating in the counter clockwise direction (fourth quadrant).

**2.1.3 Step 4 (measurement results at synchronous speed)**

When the machine was running at synchronous speed, torque, phase voltage, current, power and the power factor were all measured as shown in table 2:

**Table 2 : Torque, voltage, current, power and the power factor at  $N_s=3000$  rpm**

T (N.m)	N (rpm)	V (V)	I (A)	P (W)	Pf
-0.21	3000	237	0.14	0.8	0.018

**2.1.4 Steps 5 to 8 and 10 (load characteristics for induction machine)**

By operating the machine in motoring and generating modes with different values of loading torques, the load characteristics for the induction machines were obtained in table 3 and table 4 and the power factor was calculated by the end of each table.

**Table 3: Motoring mode operation - Y-connection**

T (N.m)	N (rpm)	V (v)	I (A)	P (W)	Pf	Pf= P/S
0	2940	237	0.17	23.8	0.595	0.5907
0.1	2910	237	0.2	34.5	0.72	0.7278
0.2	2882	237	0.24	45.7	0.8	0.8034
0.31	2848	237	0.28	56.7	0.85	0.8544
0.41	2810	237	0.33	68.4	0.881	0.8746
0.51	2765	237	0.38	81.7	0.897	0.9072
0.61	2720	237	0.44	95.3	0.91	0.9139
0.72	2655	237	0.51	110.6	0.914	0.9150
0.82	2580	237	0.59	127.5	0.916	0.9118
0.92	2481	237	0.67	146.5	0.912	0.9226

**Table 4: Generating mode operation - Y-connection**

T (N.m)	N (rpm)	V (v)	I (A)	P (W)	Pf	P/S
-0.1	2980	237.6	0.14	8.8	0.2562	0.2646
-0.2	3000	237.6	0.14	0.3	0.001	0.0090
-0.31	3030	237.6	0.16	11.2	0.301	0.2946
-0.41	3050	237.6	0.17	19.2	0.468	0.4753
-0.5	3070	237.6	0.2	26.9	0.58	0.5661
-0.62	3100	237.6	0.23	38.6	0.692	0.7063
-0.72	3120	237.6	0.27	46.4	0.733	0.7233
-0.82	3140	237.6	0.3	55	0.772	0.7716
-0.92	3160	237.6	0.33	62.7	0.795	0.7997

**2.1.5 Step 9 (Plotting load characteristics for induction machine)**

Plotting for the Torque, current, power and phase voltage against the speed for each quantity are shown in Fig.6 to Fig.9, respectively.

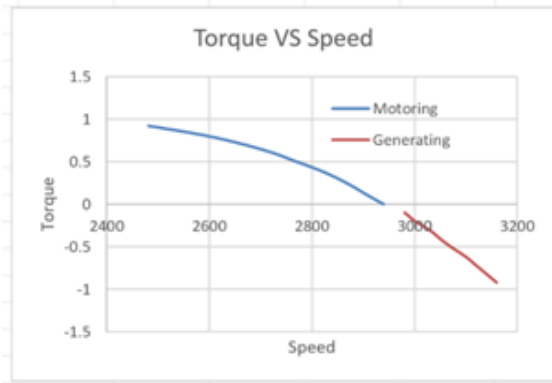

Fig.6 Torque (N.m) Vs. Speed (rpm)

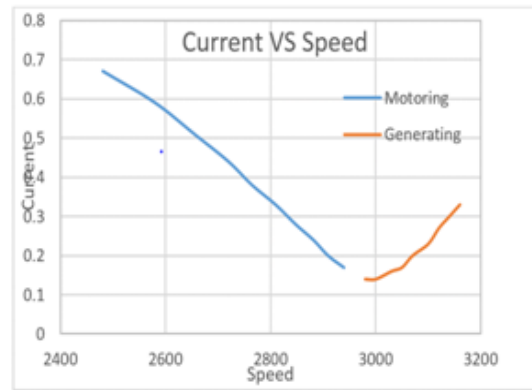

Fig.7 Current (A) Vs. Speed (rpm)

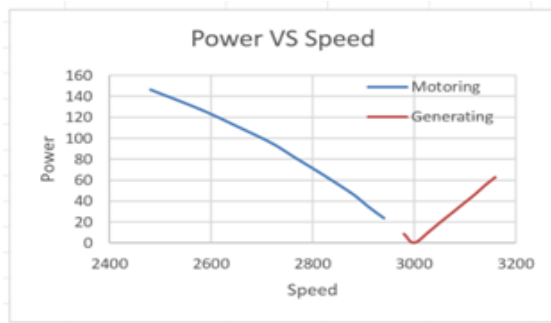

Fig.8 Power (W) Vs. Speed (rpm)

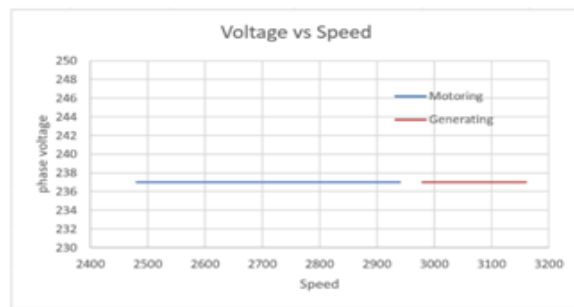

Fig.9 Power (W) Vs. Speed (rpm)

2.2 Milestone 2 (Delta connection)

In this part of the experiment, the wiring diagram is exactly the same as that of milestone 1 except that the Y-connection is replaced with delta connection for the stator windings. Again, the voltmeter was connected across a phase voltage to measure the voltage and the ammeter was connected to measure the line current. In addition, the load machine was used as a prime mover and as a mechanical load as before. Fig.10 illustrates the wiring diagram.

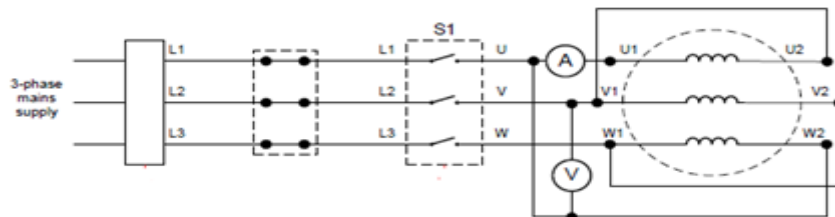

Fig.10 Schematic diagram of delta connected induction machine [7]

2.2.1 Step 1 and 2 (Line start of induction machine)

The load machine was set to motoring mode to run the machine as a motor, and loading torque was adjusted to zero. The 3-phase supply was switched on and the machine was accelerating until it settled down to rotor speed slightly less than the synchronous speed. Table 5 summarizes the results.

Table 5: Rotor speed, synchronous speed and the slip

Rotor speed (measured)	Synchronous speed (Calculated) $N_s = 120 * \frac{f}{p}$	Slip $S = \frac{N_s - N_R}{N_s}$
2987 rpm	$N_s = 120 * \frac{50}{2} = 3000 \text{ rpm}$	$S = \frac{(3000 - 2987)}{3000} = 0.0433$

**2.2.2 Step 3 (Identifying the direction of operation for induction machine)**

When the load machine was adjusted to speed control mode, and by adding a positive torque, the speed was decreasing and rotating in clockwise direction (1st quadrant). On the other hand, when a negative torque added the speed was increasing and rotating in the counter clockwise direction (fourth quadrant).

**2.2.3 Step 4 (measurement results at synchronous speed)**

When the machine was running at synchronous speed, torque, phase voltage, current, power and the power factor were measured as shown in table 6:

**Table 6: Torque, voltage, current, power and the power factor at  $N_s=3000$  rpm**

T (N.m)	N (rpm)	V (V)	I (A)	P (W)	Pf
-0.23	3000	407.8	0.33	1.4	0.009

**2.2.4 Steps 5 to 8 and 10 (load characteristics for induction machine)**

By operating the machine in motoring and generating modes with different values of loading torques, the load characteristics for the induction machines were obtained in table 7 and table 8 in and the power factor was calculated by the end of each table.

**Table 7 : Motoring mode operation -  $\Delta$ -Connection**

T (N.m)	N (rpm)	V (v)	I (A)	P (W)	Pf	Pf= P/S
0	2940	408	0.17	23.8	0.595	0.5907
0.1	2977	408.3	0.33	38.6	0.281	0.2865
0.2	2966	408	0.34	49	0.358	0.3532
0.31	2957	409	0.35	60	0.428	0.4191
0.41	2947	408.5	0.35	70	0.489	0.4896
0.51	2937	408	0.36	80	0.542	0.5447
0.61	2925	407.4	0.38	90.9	0.592	0.5872
0.72	2914	407.2	0.39	102.2	0.64	0.6435
0.82	2903	407.9	0.41	114.7	0.682	0.6858
0.92	2888	407.4	0.43	127	0.725	0.7250

**Table 8: Generating mode operation -  $\Delta$ -Connection**

T (N.m)	N (rpm)	V (v)	I (A)	P (W)	Pf	P/S
-0.1	2990	407.5	0.33	16.6	0.127	0.1234
-0.23	3000	407.8	0.33	1.4	0.009	0.0104
-0.28	3000	407.7	0.34	1	0.001	0.0072
-0.4	3010	408	0.35	11.3	0.089	0.0791
-0.51	3020	407.6	0.36	22.8	0.154	0.1554
-0.63	3030	407	0.37	35	0.236	0.2324
-0.68	3031	407.7	0.37	36.1	0.243	0.2393
-0.82	3040	407.7	0.39	47.7	0.299	0.3000
-0.91	3050	407.2	0.4	56.4	0.34	0.3463

**Table 8: Generating mode operation -  $\Delta$ -Connection**

**2.2.5 Step 9 (Plotting load characteristics for induction machine)**

Plotting for the Torque, current, power and phase voltage against the speed for each quantity are shown in Fig11. to Fig.14, respectively.

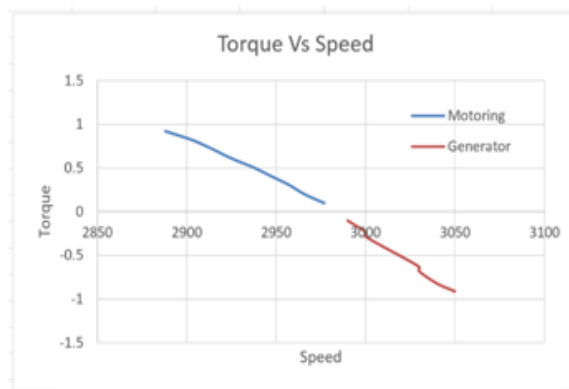

Fig.11 Torque (N.m) Vs. Speed (rpm)

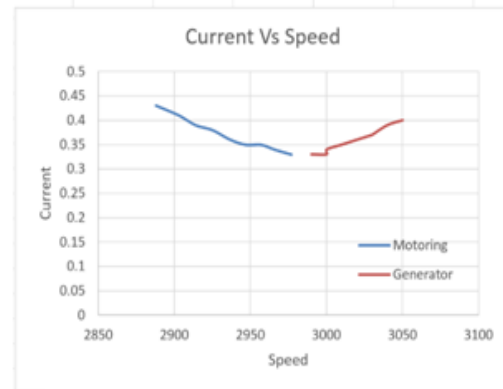
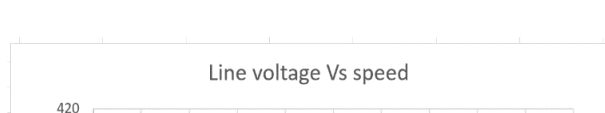
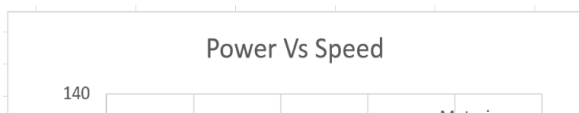

Fig.12 Current (A) Vs. Speed (rpm)



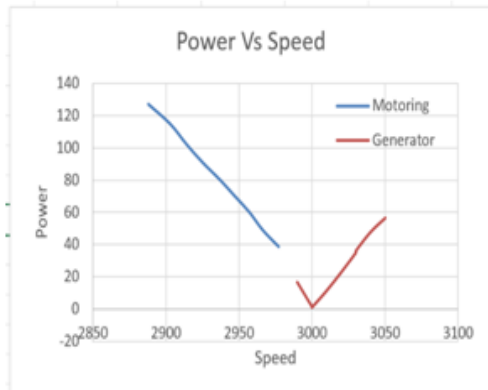

Fig.13 Power (W) Vs. Speed (rpm)

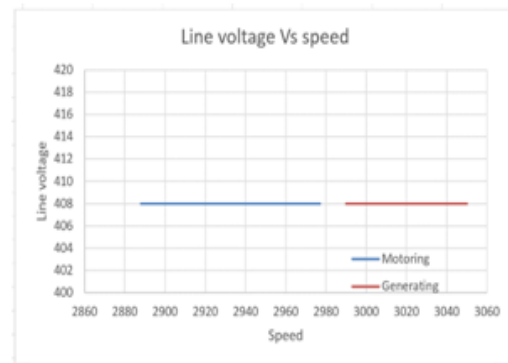

Fig.14 Phase voltage (V) Vs. Speed (rpm)

### 2.3 Milestone 3 (Line start transient)

In this part of the experiment, the starting line current drawn from the 3-phase power supply for delta connected induction machine was measured and observed using the oscilloscope. The starting current represents the maximum current during the transient period. Fig.15 shows a capture from the oscilloscope for the starting line current with a time base of 20 ms/cm.

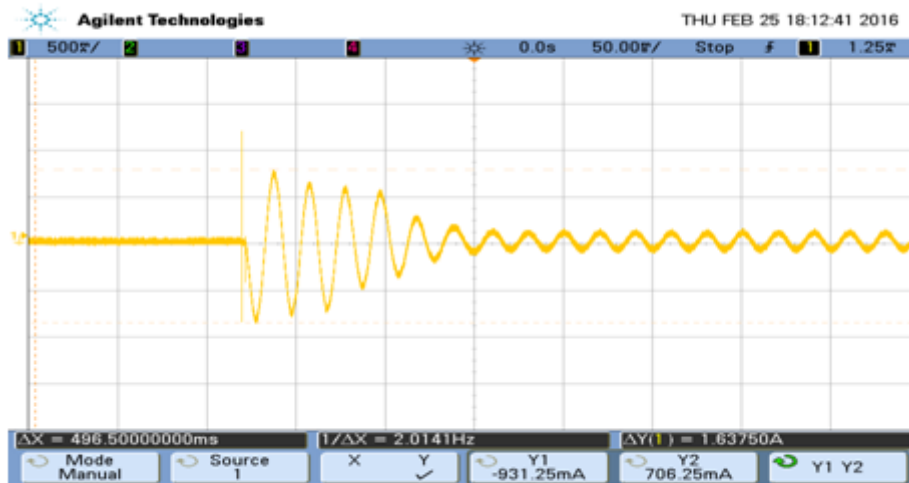

Fig.15 starting stator current during transient period

### 2.4 Milestone 4: Reactive power compensation

In this part of the experiment, 3-phase star connected capacitor load was connected to the stator windings of the induction machine when connected in Y-connection to improve the low power factor of the machine. Fig.16 shows the wiring diagram for this milestone.

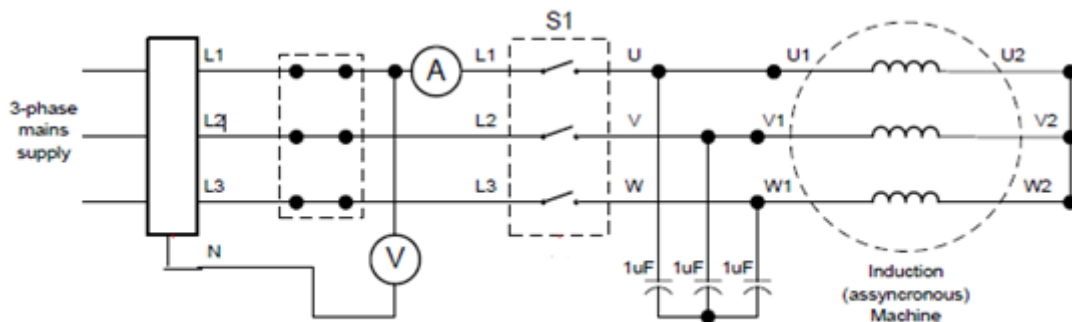

Fig.16 Schematic diagram of star connected induction machine with compensated capacitor bank [7]



**2.4.1 Step 1 and 2 (Line start of induction machine)**

The load machine was set to motoring mode to run the machine as a motor, and loading torque was adjusted to zero. The 3-phase supply was switched on and the machine was accelerating until it settled down to rotor speed slightly less than the synchronous speed. Table 9 summarizes the results.

**Table 9 : Rotor speed, synchronous speed and the slip**

Rotor speed (measured )	Synchronous speed (Calculated) $N_s = 120 * \frac{f}{p}$	Slip $S = \frac{N_s - N_R}{N_s}$
2947 rpm	$N_s = 120 * \frac{50}{2} = 3000$ rpm	$S = \frac{(3000 - 2947)}{3000} = 0.01767$

**2.4.2 Step 3 (Identifying the direction of operation for induction machine)**

When the load machine was adjusted to speed control mode, and by adding a positive torque, the speed was decreasing and rotating in clockwise direction (1st quadrant). On the other hand, when a negative torque added the speed was increasing and rotating in the counter clockwise direction (fourth quadrant).

**2.4.3 Step 4 (measurement results at synchronous speed)**

When the machine was running at synchronous speed, torque, phase voltage, current, power and the power factor were all measured as shown in table 6:

**Table 10: Torque, voltage, current, power and the power factor at  $N_s=3000$  rpm**

T (N.m)	N (rpm)	V (V)	I (A)	P (W)	Pf
-0.17	3000	236.5	0.07	2.4	0.127

**2.4.4 Steps 5 to 8 and 10 (load characteristics for induction machine)**

By operating the machine in motoring and generating modes with different values of loading torques, load characteristics for the induction machines were obtained in table 11 and table 12 in and the power was calculated by the end of each table.

**Table 11: Motoring mode operation - Q compensation**

T (N.m)	N (rpm)	V (v)	I (A)	P (W)	Pf	Pf= P/S
0	2947	235.3	0.12	22.9	0.82	0.8110
0.1	2920	236.6	0.15	33.9	0.9	0.9552
0.2	2888	236.2	0.2	44.5	0.937	0.9420
0.31	2850	235.5	0.25	55.3	0.956	0.9393
0.41	2814	236	0.3	67.5	0.958	0.9534
0.51	2770	236.6	0.36	81	0.962	0.9510
0.61	2720	236.6	0.42	94.4	0.962	0.9500
0.72	2659	236.4	0.49	110.2	0.959	0.9513
0.82	2582	236.2	0.56	126.6	0.956	0.9571
0.92	2480	236.1	0.65	146.1	0.949	0.9520

**Table 12: Generating mode operation - Q compensation**

T (N.m)	N (rpm)	V (v)	I (A)	P (W)	Pf	P/S
-0.1	2980	236.2	0.08	9.2	0.52	0.4869
-0.18	3000	235.8	0.07	1.8	0.1	0.1091
-0.22	3010	236	0.07	3.6	0.228	0.2179
-0.31	3030	235.9	0.09	11.8	0.556	0.5558
-0.4	3050	235.5	0.11	19.4	0.723	0.7489
-0.5	3070	235.6	0.14	26.4	0.795	0.8004
-0.6	3100	236.1	0.19	37.7	0.858	0.8404
-0.7	3120	235.7	0.22	46.6	0.881	0.8987
-0.8	3140	236	0.26	53.7	0.892	0.8752
-0.9	3160	236	0.29	61.7	0.9	0.9015

**2.4.5 Step 9 (Plotting load characteristics for induction machine )**

Plotting for the Torque, current, power and phase voltage against the speed for each quantity are shown in Fig17. to Fig.20, respectively.



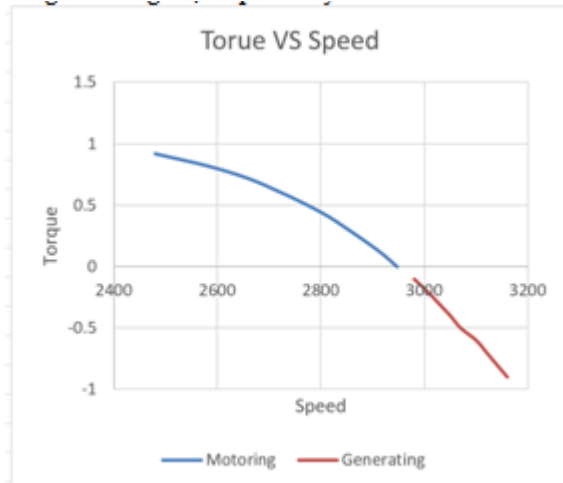

Fig.17 Torque (N.m) Vs. Speed (rpm)

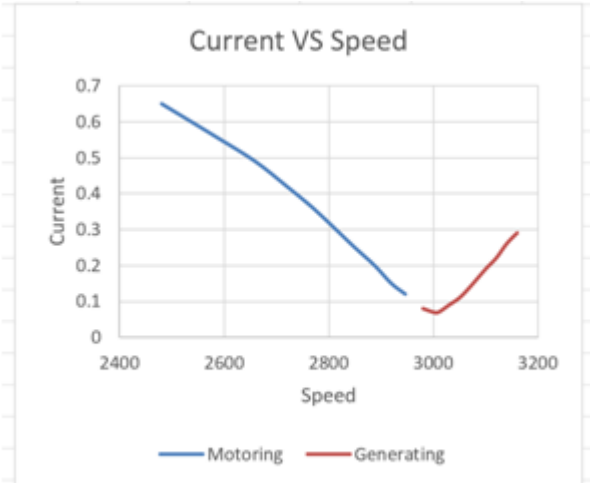

Fig.18 Current (A) Vs. Speed (rpm)

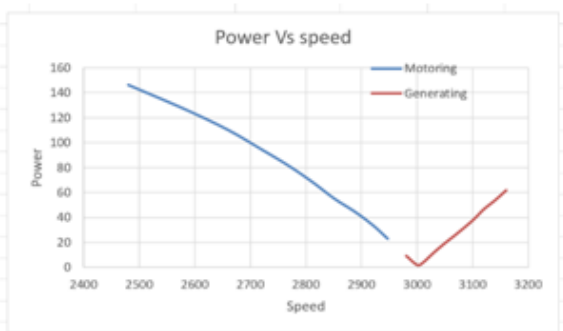

Fig. Power (W) Vs. Speed (rpm)

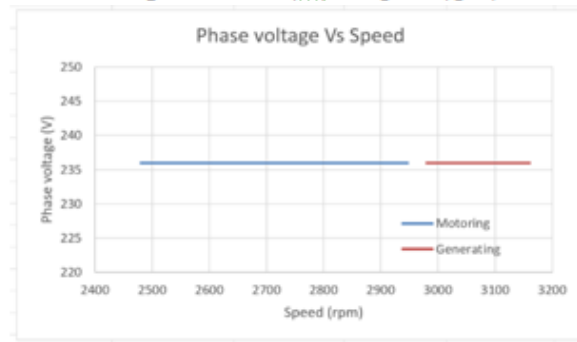

Fig.20 Phase voltage (V) Vs. Speed (rpm)

### III. DISCUSSION

#### 3.1 Milestone 1: star connection

##### 3.1.1 Step 1 and 2 (Line start of induction machine)

When load machine was set to motoring mode with a zero-load applied to the induction machine and the power supply switched on, the machine was accelerating until it settled down to rotor speed slightly less than the synchronous speed. Since, the machine has 2 poles, the slip ( $S$ ) and the synchronous speed ( $N_s$ ) were calculated as it was shown on table according to the equations (4) and (5) in the introduction[1] :

$$S = \frac{N_s - N_R}{N_s} \quad (4)$$

$$N_s = 120 \frac{f}{p} \quad (5)$$

##### 3.1.2 Step 3 (Identifying the direction of operation for induction machine)

When the load machine was adjusted to speed control mode, and by adding a positive torque, the speed was decreasing and rotating in clockwise direction (1st quadrant). On the other hand, when a negative torque added the speed was increasing and rotating in the counter clockwise direction (fourth quadrant). Fig.21 shows the four-quadrant operation of induction machine.

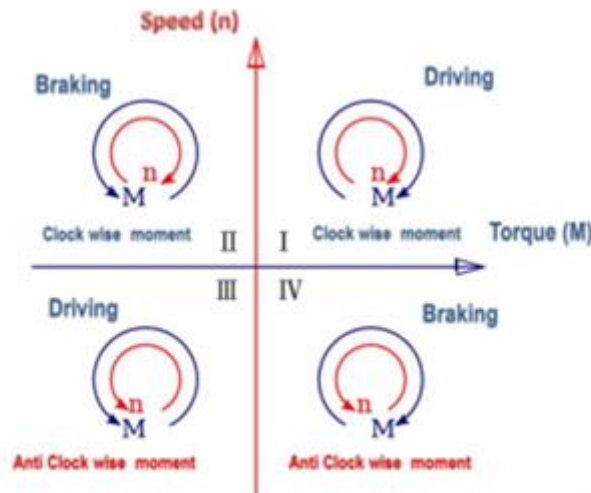

Fig.21 Four quadrant operation of induction machine. Adapted from "https://www.bing.com"

### 3.1.3 Steps 4 to 10 (load characteristics for induction machine)

When the induction machine was loaded with a positive torque, the speed was decreasing. This is because the slip of the machine in this arrangement will have a value between 0 to 1, since  $N_s$  and  $N_r$  in the same direction, and the speed accordingly will be calculated if we solve for eq. (4):

$$N_r = N_s * (1 - S) \quad , \text{ slip values: 0 to 1 in motor mode} \quad (6) \quad [1]$$

- On the other hand, when the induction machine was loaded with a negative torque, the machine speed was increasing because the rotor speed rotating against the direction of the synchronous speed which makes the slip greater than 1. Hence, this is why the rotor speed was increasing if we substitute again in eq. (6).
- Also, the speed of the machine will change with the change of the loading torque according to the following equation:

$$\omega(t) = \frac{T_E - T_{Load}}{c} \left( 1 - e^{-\left(\frac{t}{\tau}\right)} \right) \quad (7) \quad [6]$$

- The current in the machine was increasing with increase of the positive/negative torque according to the following equation:

$$T = k \phi I_a \quad (8) \quad [5]$$

- The input power (in motor mode operation) in the machine was rising with increase of the load because the current was increasing while the stator voltage was fixed according to the following formula:

$$P = I V \cos \phi \quad (9)$$

and it is the output power in generator mode operation.

- In addition, the output power (in motor mode operation) was increasing due to rise of the loading torque according to the following formula :

$$P = T \omega \quad (10)$$

and it is the input power in generator mode operation.

- The power factor in the machine indicates the parentage of the active real power P in the system. The power factor was inclining with the increase of the positive/negative mechanical/electrical loading because the latter is simply an addition of a mechanical/electrical power P to the machine, which is a real power. In addition, the power factor depends on the angle  $\phi$  between the current I and the input voltage V and it was increasing because of the reduction of the phase angle  $\phi$  between V and I.

- The power factor can be calculated as in equation (6):

$$P.f = \cos \phi = \frac{P}{IV} \quad (11)$$

### 3.2 Milestone 2 : Delta connection

#### 3.2.1 Step 1 and 2 (Line start of induction machine)

The same discussion and analysis applies as in section 3.1.1 of steps 1 to 2 in star connected induction machine with remark that rotor speed is slightly more than that of star connected induction machine. (More in details in section 3.2.4)

#### 3.2.2 Step 3 (Identifying the direction of operation for induction machine)

The same discussion and analysis apply as in section 3.1.2 of step 3 in star connected induction machine.

#### 3.2.3 Steps 4 to 10 (load characteristics for induction machine)

The same discussion and analysis apply as in section 3.1.3 of steps 4 to 10 in star connected induction machine. (More details in section 3.2.4)

#### 3.2.4 Comparison between Y-connection and Δ-connection of induction motor

From the data in **tables and graphs** of milestone 1 and milestone 2, the comparison between the two types as follow:

- The Δ-connected induction machine has a phase voltage greater than Y-connected induction machine by a factor of  $\sqrt{3}$  since:

$$V_{L-L} = \sqrt{3}V_{\phi} \quad (\text{for Y-connection}) \quad (12)$$

$$V_{L-L} = V_{\phi} \quad (\text{for } \Delta\text{-connection}) \quad (13)$$

For Y-connection  $V_{\phi}$  was 237 V, and for Δ-connection it was 408 V. Thus, less insulation will be needed for the windings of the stator when connected in Y which will minimize the cost. Therefore, the windings in delta connection will heat in more amount than that of its counterpart in Y-connection for the same input voltage ratings, which means high losses in the machine according to the following formula:

$$P = \frac{V^2}{R} \quad (14)$$

- The line current in the Δ-connection of the induction machine was greater than that of Y-connection. (11). Therefore, the starting current was necessary to be observed and analyzed in milestone 3 since the starting current in 3-phase induction machine is usually 3 to 4 times its full load current. [2].

- Since the phase voltage V in the induction machine is directly proportional to the rotor speed  $\omega$  according to the following equation:

$$V = k \phi \omega \quad (15) \quad [5]$$

Hence, this is why the rotor speed was found to be higher in the delta connected machine than that of Y connected.

### 3.3 Milestone 3: Line Transient current

In this part of the experiment, the starting line current drawn from the 3-phase power supply for delta connected induction machine was measured and observed using the oscilloscope. The startup remained within operating for the 1st two or three cycles as shown in Fig.15. The time base of 20 ms/cm represents reciprocal of the input frequency which is 50 Hz. From Fig.15, the  $\Delta Y(1) = 1.6375$  A is the starting current drawn from supply. If the full load current from table 7 is considered to be 0.43 at T=0.92 N.m, then:

$$\frac{I_{\text{start}}}{I_{\text{FL}}} = \frac{1.6375}{0.43} = 3.8 \quad [2]$$

Thus, the starting current is greater than the full load current by almost 4 times! Therefore, when designing the induction machine, it is very important to consider the value of the starting current that can be drawn by the machine so to make the necessary means to protect the stator winding from overheating if the starter period takes too long. In addition, the starting current for some 1 $\phi$  induction machine is even worse. For example, the starting current for single split induction motor is usually 7 to 8 times of the full load current. Therefore, the starting inductor is fitted with a thermal relay in series in order to protect the circuit from an excessive amount of current if the time of the starting period exceeded 10 seconds! The problem is also can be solved by connecting a capacitor in series with starting inductor and which makes the starting torque bigger [2], [3].

### 3.4 Milestone 4 : Reactive power compensation

The 3-induction machines usually tend to have low power factor where they affect the overall power factor of the network if they are found in large numbers with high ratings in the network. This is because they draw the necessary reactive power for the magnetization in their windings in addition to the active power they consume. For single phase induction machines, the situation is even worse especially when they run at no load because of the large magnetization currents they carry. Thus, capacitor banks, or some over excited synchronous motors running at no load are usually placed in the network to compensate the low power factor [1].

#### 3.4.1 Step 1 and 2 (Line start of induction machine)

The same discussion and analysis applies as in section 3.1.1 of steps 1 to 2 in star connected induction machine.

#### 3.4.2 Step 3 (Identifying the direction of operation for induction machine)

The same discussion and analysis apply as in section 3.1.2 of step 3 in star connected induction machine.

#### 3.4.3 Steps 4 to 10 (load characteristics for induction machine)

The same discussion and analysis apply as in section 3.1.3 of steps 4 to 10 in star connected induction machine.

#### 3.4.4 Comparison between Y-connections induction machine before and after adding the compensating capacitors.

- After adding the capacitors bank, the power factor was improved significantly. This is because the capacitors delivering a negative reactive power to induction machine which opposes the positive reactive power in the machine. Hence, the total reactive power will be minimized according to the reactive power flow in the machine:

$$Q_{\text{tot}} = Q_L + (-Q_C) \quad (!6)$$

The angle  $\phi$  of the power factor between the voltage and the current in the machine is the same of that angle between the active power P and apparent power S according the power triangle as shown in Fig.22. Therefore, less reactive power makes  $\cos \phi$  relatively bigger [1], [4].

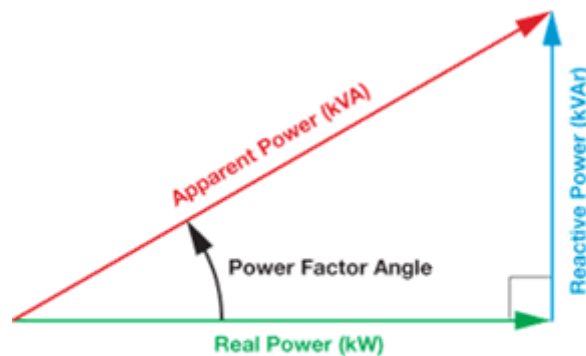

Fig. 22 Power triangle. Adapted from  
["https://www.bing.com"](https://www.bing.com)

In addition, the current drawn from the supply was decreased notably after adding the capacitor bank. This advantage is very important in minimizing the cross-sectional area of the conductors of the stator windings according to the formula:

$$R = \frac{\rho L}{A} \quad (17)$$

- The active power almost did not change after adding the capacitors to the induction machine. This is because the capacitor is an element which supply only reactive power Q . The active power P is supplied from the electrical loading (negative torque) or by the mechanical loading (positive torque) and the losses in the machine where both the electrical and the mechanical loadings added in the same amount for each torque loading value.

- There is almost no considerable effect on the speed of rotor.

#### IV. CONCLUSION

The milestones in this paper were accomplished to investigate the performance of the induction machine under several operating conditions. The load characteristics of the induction machine in both motoring mode and generating mode for star and delta connection were analyzed practically and justified theoretically, where both the phase voltage and the rotor speed were found to be relatively greater in the delta connection. In addition, the startup line current for delta connected induction machine was investigated and it was found to be 4 times the full load current. Furthermore, the power factor was improved, and the line current was reduced when a 3-phase capacitor bank was added to the induction machine. Moreover, the machine parameters that were involved in this experiment are: Torque, speed, phase voltage, line current, power and the power factor, where the measurements and the calculations of the stator resistance and inductance were not included.

#### REFERENCES

- [1]. Theodore Wildi , Electrical Machines , Drives , And Power Systems , Pearson
- [2]. Prentice Hall, 6<sup>th</sup> Edition, 2006.
- [3]. Theodore Wildi. P. Eng. And The Staff of Lab-Volt Ltd, Electrical Power Technology Volume 4 Three Phase Transformer and AC machines, 1st Edition, 1987.
- [4]. Theodore Wildi. P. Eng. And The Staff of Lab-Volt Ltd, Electrical Power Technology Volume 3 Single-Phase Transformers and AC Machines, 1st Edition, 1987.
- [5]. Theodore Wildi. P. Eng. And The Staff of Lab-Volt Ltd, Electric Power Transmission System, 2nd Edition, March 2007.
- [6]. Stephen J. Chapman , electrical machinery fundamentals, Pearson , 5th edition
- [7]. Dr. Glynn Atkinson, Handout of Module EEE8016, School Of Electrical And Electronic Engineering, Newcastle University, 2015.
- [8]. Dr. Kabita Adhikari, Handout of Module EEE8074, School Of Electrical And Electronic Engineering, Newcastle University, 2016.

#### VI Appendix

---

##### 6.1 Appendix 1 ( Machines specifications )

specifications	Values
Rated power	0.37Kw
Rated voltage	690/400 V ,50 Hz
Rated current	0.6/1 A
power factor	0.83
Rated speed	2800 rad/sec

**Table 13** : Specification of induction machine

6.2 Appendix 2

Terms in equations

eq(1):

- $V_{induced}$  = induced voltage (V)
- $f$  = frequency of the rotor (Hz)
- $N$  = number of turn for the winding per phase
- $\Phi_{max}$  = the peak value of the magnetic field.
- 4.44 = a constant

eq(2) and eq(3) :

- $I_2$  = current in the rotor windings (A)
- $s$  = slip factor
- $E_2$  = the voltage across the rotor windings (v)
- $R_2$  = rotor's resistor ( $\Omega$ )
- $X_2$  = rotor's reactance ( $\Omega$ )
- $T$  = torque of the motor (N.m)
- $\omega_s$  = synchronous speed (rad/sec)

eq(4), eq(5) and eq(6) :

- $s$  = slip factor
- $N_s$  = the synchronous speed (rpm)
- $N_r$  = speed of the motor (rpm)
- $p$  = number of poles in the stator
- $f$  = frequency of the source (Hz)

eq(7) and eq(8)

- $\omega(t)$  = speed (rad/sec)
- $T_E$  = electrical load (N.m)
- $T_L$  = mechanical load (N.m)
- $C$  = losses coefficient -
- $t$  = time (s),  $\tau$  = time constant (s)
- $T$  = Torque (N.m),  $k$  = constant ,
- $\Phi$  = flux (wb),  $I_a$  = Armature current (A)

eq(9), eq(10) and eq(11)

- $P$  = electrical power (w)
- $I$  = Line current (A)
- $V$  = terminal voltage (v)
- $T$  = Torque (N.m)
- $\cos\phi$  = power factor
- $\omega$  = speed (rad/sec)

eq(12), and eq(13) :

- $V_{L-L}$  = line to line voltage (V)
- $V_{\phi}$  = phase voltage (V)

and eq(14) :

- $P$  = power losses (W)
- $V$  = rated voltage (V)
- $R$  = Resistance ( $\Omega$ )

and eq(15):

- $\omega$  = speed (rad/sec),  $k$  = constant ,
- $\Phi$  = flux (wb),
- $V$  = induced voltage

eq(16) :

- $Q_L$  = inductive reactive power (VAR)
- $Q_C$  = Capacitive reactive power (VAR)
- $R$  = resistance (Ohm),  $\rho$  = resistivity
- $L$  = length (m),  $A$  = Area ( $m^2$ )

**Index of Figures**

Fig.1(a) A stator of induction machines showing its windings	1
Fig.1(b) A schematic diagram of a 6-pole stator and its windings	1
Fig.2 Rotor for 3-phase induction motor. (a) squirrel cage rotor (b) wound rotor	1
Fig.3 Wound rotor for induction circuit diagram	2
Fig.4 Torque speed characteristics for 3-phase induction machine	2
Fig.5 Schematic diagram of star connected induction machine	3
Fig.6 Torque (N.m) Vs Speed (rpm)	4
Fig.7 Current (A) Vs Speed (rpm)	4
Fig.8 Power (W) Vs Speed (rpm)	5
Fig.9 Phase voltage (V) Vs Speed (rpm)	5
Fig.10 Schematic diagram of delta connected induction machine	5
Fig.11 Torque (N.m) Vs Speed (rpm)	7
Fig.12 Current (A) Vs Speed (rpm)	7
Fig.13 Power (W) Vs Speed (rpm)	7
Fig.14 Phase voltage (V) Vs Speed (rpm)	7
Fig.15 Starting stator current during transient	7
Fig.16 Schematic diagram of star connected induction machine with compensated capacitor bank	8
Fig.17 Torque (N.m) Vs Speed (rpm)	9
Fig.18 Current (A) Vs Speed (rpm)	9
Fig.19 Power (W) Vs Speed (rpm)	10
Fig.20 Phase voltage (V) Vs Speed (rpm)	10
Fig.21 four quadrant operation of induction machine	10
Fig.22 Power triangle	13

**Index of Tables**

Table 1: Rotor speed, synchronous speed and the slip	3
Table 2: Torque, voltage, current, power and the power factor at NS=3000 rpm	4
Table 3: Motoring mode operation - Y-connection	4
Table 4: Generating mode operation- Y-connection	4
Table 5: Rotor speed, synchronous speed and the slip	5
Table 6: Torque, voltage, current, power and the power factor at NS=3000 rpm	6
Table 7: Motoring mode operation - Δ-Connection	6
Table 8: Generating mode operation - Δ-Connection	6
Table 9: Rotor speed, synchronous speed and the slip	8
Table 10: Torque, voltage, current, power and the power factor at NS=3000 rpm	8
Table 11: Motoring mode operation - Q compensation	9
Table 12: Generating mode operation - Q compensation	9
Table 13: Specification of induction machine	15

**Table of contents**

Content	Page No
<b>Abstract</b>	
<b>I. Introduction</b>	<b>1</b>
1.1 Three phase induction machine	1
1.2 Principle of operation	2
1.3 Slip in the induction motor	2
1.4 Starting current for induction machine	3
<b>II. Method and Results</b>	<b>3</b>
2.1 Milestone 1 (Starconnection)	3
2.1.1 Step 1 and 2 (Line start of induction machine)	4
2.1.2 Step 3 (Identifying the direction of operation for induction machine)	4
2.1.3 Step 4 (measurement results at synchronous speed)	4
2.1.4 Steps 5 to 8 and 10 (load characteristics for induction machine)	4
2.1.5 Step 9 (Plotting load characteristics for induction machine)	5
2.2 Milestone 2 (Delta connection)	5
2.2.1 Step 1 and 2 (Line start of induction machine)	6
2.2.2 Step 3 (Identifying the direction of operation for induction machine)	6
2.2.3 Step 4 (measurement results at synchronous speed)	6
2.2.4 Steps 5 to 8 and 10 (load characteristics for induction machine)	6
2.2.5 Step 9 (Plotting load characteristics for induction machine)	7
2.3 Milestone 3 (Line start transient)	7
2.4 Milestone 4: Reactive power compensation	8
2.4.1 Step 1 and 2 (Line start of induction machine)	8
2.4.2 Step 3 (Identifying the direction of operation for induction machine)	8
2.4.3 Step 4 (measurement results at synchronous speed)	9
2.4.4 Steps 5 to 8 and 10 (load characteristics for induction machine )	9
2.4.5 Step 9 ( Plotting load characteristics for induction machine )	9
<b>III. Discussion</b>	<b>10</b>
3.1 Milestone 1: star connection	10
3.1.1 Step 1 and 2 (Line start of induction machine)	10



3.1.2 Step 3 (Identifying the direction of operation for induction machine)	10
3.1.3 Steps 4 to 10 (load characteristics for induction machine)	11
3.2 Milestone 2: Delta connection	11
3.2.1 Step 1 and 2 (Line start of induction machine)	11
3.2.2 Step 3 (Identifying the direction of operation for induction machine)	11
3.2.3 Steps 4 to 10 (y load characteristics for induction machine)	11
3.2.4 Comparison between Y-connection and $\Delta$ -connection of induction motor	11
3.3 Milestone 3: Line Transient current	12
3.4 Milestone 4: Reactive power compensation	12
3.4.1 Step 1 and 2 (Line start of induction machine)	12
3.4.2 Step 3 (Identifying the direction of operation for induction machine)	12
3.4.3 Steps 4 to 10 (load characteristics for induction machine)	12
3.4.4 Comparison between Y-connections induction machine before and after adding the compensating capacitors.	12
<b>IV. Conclusion</b>	<b>13</b>
V. References	14
VI. Appendix	15
6.1 Appendix 1	15
6.2 Appendix 2	15
Index of Figures	16
Index of Tables	16
Table of contents	17

Hani Y. Alfahed, "Investigating the Performance of the 3-Phase Induction Machine"  
*The International Journal of Engineering and Science (IJES)*, 8.12 (2019): 81-96.