

## Energy-efficient Underwater ROV with a Self-adjustable Two-axis Rudder for Flow Adaptation

Christy Sum Yu Cheung<sup>1</sup>

<sup>1</sup> Shanghai American School, Shanghai, China

### -----ABSTRACT-----

*A hundred million tons of microplastics contaminate the ocean. Besides causing environmental pollution, microplastics are also ingested by plankton and fish and transferred up the food chain to humans. Submersible robots can be equipped with tools to capture microplastics as they enter the ocean and assess potential environmental hazards. During long underwater cleanup missions, flow disturbances and energy consumption are inevitable concerns. This work investigates how rotating a top-mounted, two-axis rudder allows an underwater vehicle to adapt to water flows and optimize energy consumption. The proposed robot can increase its travel speed with or against flows by self-adjusting its rudder rotation. When traveling in the same direction as the flow, the robot is assisted by the flow when its rudder is perpendicular to the flow, traveling up to 37% faster than its other forms. When walking against flows, the robot can travel up to 80% faster than its other forms when its rudder is parallel to the flow direction. The robot can also determine if it is facing towards or away from the flow using a flow rate sensor and correctly self-adjust the rudder to the preprogrammed angle that helps it travel fastest in the desired direction 60% to 80% of the time. By self-adjusting the rudder, the robot can quickly adapt to travel faster with or against water flows. The robot also minimizes energy consumption when it uses the least time to travel a fixed distance. The flow-adaptive and energy-efficient rudder robot can help stably capture microplastics for long mission duration.*

**KEYWORDS;** *Two-axis rudder, incident angle, self-adjustable, flow adaptation, energy optimization*

Date of Submission: 02-09-2023

Date of acceptance: 14-09-2023

### I. INTRODUCTION

An estimated 75 to 199 million tons of plastic currently pollute the ocean [1]. The United Nations estimates that the volume of plastic entering the ocean per year will double or even triple by 2040 [2]. Many people have seen photos of plastic products strangling dolphins, suffocating sea turtles, or hurting marine life in other ways. However, less attention is concentrated on microplastics, which are plastic debris of less than five millimeters. Besides causing environmental pollution, microplastics are also ingested by plankton and fishes and transferred up the food chain to humans [3]. Microplastics are not just in seafood, but also in drinking water. There are three types of microplastics: fragments of larger plastic, plastic pellets from production – like microbeads in cosmetics – or byproducts produced during plastics usage, like synthetic fibers released from clothing during laundry [4]. In fact, microfibers transported into the ocean by laundry wastewater are a significant yet overlooked culprit of microplastic pollution, as wastewater treatment plants are currently ineffective in filtering microplastic out of the wastewater. A study done by plastic pollution specialist and researcher Beizhan Yan discovered that more than 90% of the microplastics greater than 0.2 millimeters in New York City waters were microfibers from clothing [5].

NASA has deployed a Cyclone Global Navigation Satellite System to identify areas with large volumes of microplastic. A German company, Wasser 3.0, uses a non-toxic compound to clump microplastics, allowing them to be more easily collected. Researchers around the world are developing magnets, vacuums, nets, and other filter tools that can capture microplastics [1, 6]. Controlling the pollutant at its origin would be a cost-efficient approach to managing microplastic pollution. The recycled microfibers could even be repurposed into new fibers for use. However, even with the support of these methods, deploying human divers to pick up plastic waste in marine areas is an inefficient solution. It is slow, and divers can only stay underwater for a limited duration. Furthermore, areas like sewage systems or rapid waterways are dangerous for human divers due to unpredictable water flows and contamination. Instead, using underwater remotely operated vehicles (ROVs) and robots to replace humans in underwater cleanup and monitoring missions would increase efficiency, safety, and mission durations. Submersible robots can be equipped with filter equipment, special compounds, or magnets developed by researchers to capture microplastics before, during, or after they enter the ocean as well as assess potential environmental hazards during the cleanup missions [7].

Unlike typical terrestrial robots, aquatic robots must be waterproof and versatile to function in various underwater conditions. In the face of flow disturbances, underwater vehicles are prone to deviating from their original position as the flows can be rapid, turbulent, or unpredictable. Currently, there are a few common approaches to help a submersible vehicle or robot travel in flows.

Underwater propeller ROVs are among the most common underwater commercial technology. These typically use propellers or thrusters for propulsion and position-adjusting, allowing for high speed, agility, and control. However, when traveling in stronger water flows, these vehicles readjust their deviated position using multiple thrusters, expending a large amount of energy when traveling long distances in flows. For example, VideoRay's Mission Specialist Defender ROV uses as many as seven thrusters for positioning [8]. These vehicles are usually tethered to power supplies on land or a vessel using expensive umbilical cords to satisfy their high energy demands. Though reliable, these typical ROVs are energy-consuming and expensive. Additionally, thrusters face the risk of entanglement by seaweeds or loose articles in the water. Another highly researched field is biomimetic robotics. These robots imitate the properties of animals, often mimicking the swimming of a fish or ray [9, 10] by undulating its body and artificial fins or the crawling of an octopus or crab [11, 12]. The imitation of marine animals results in unobtrusive, energy-efficient robots [13]. However, these robots often passively adapt to flows by constantly adjusting their position – similar to thruster ROVs – or transforming its body to better respond to flows. Although biomimetic robots are better suited to adjust to the direction of water flows, research on these robots has been limited to small-size robots that are unsuitable for carrying additional equipment. Underwater-legged robots are usually designed to traverse the bottom of waterways or for amphibious robots [14]. The legs rely on the frictional force between the robot and the underlying surface to counteract disturbances acting on the robot [15]. Although the legs allow the robots to navigate in terrestrial and aquatic terrains, solely relying on friction with the ground may not suffice on surfaces with sand, mud, or friction-decreasing substances.

Hence, This work aims to design an energy-efficient and scalable underwater remotely operated vehicle (ROV) for flow adaptation – helping it travel faster in the same direction as the flow or against it – and carrying additional equipment to safely and efficiently capture microplastics in sewages and riverbeds.

Increasing travel efficiency by rotating the rudder aims to optimize the vehicle's energy consumption, allowing the vehicle to traverse great distances using the least amount of time and energy. Successful flow adaptation is shown by maximizing the vehicle's travel speed when walking in the same direction or against a water flow by adjusting the angle that the robot's top component makes with the oncoming horizontal flow. The energy-efficient feature is shown by minimizing the time, and thus energy, required for the ROV to travel a fixed distance with or against a water flow. Scalable is defined as a mechanical structure that can be made in different sizes and retain its function. Theoretically, the robot expends a consistent amount of energy when the battery is sufficiently charged. Therefore, if the robot adjusts to the form that uses the least time – compared to its other forms – to travel a fixed distance, it minimizes energy consumption in that form.

This robot can serve as a vehicle to capture microplastic and assess potential environmental hazards. It can be equipped with tools to collect and isolate microplastics from polluted waters in sewage systems, rivers, streams, or the ocean. To better accommodate for the water flows that the robot inevitably will be faced with regardless of the body of water, this robot adjusts a top-mounted component to travel faster in the desired direction: with or against the water flow. In short, this robot aims to minimize its time and energy consumption during microplastic cleanup missions by self-adjusting to the water flow's direction.

## II. METHODOLOGY

The proposed method is a four-legged underwater ROV with a top-mounted rudder that can be rotated on two axes, which alters the incident angle of the water flow in relation to the rudder. The incident angle is the angle between the direction of the horizontal water flow and the surface of the vehicle's rudder. Altering the incident angle could help the robot travel faster with or against the flow.

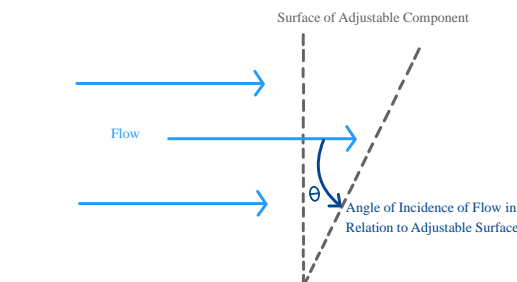

Fig. 1.  $\theta$  is the incident angle

**A. Two-axis Rudder**

The rudder robot uses a top-mounted rudder board that may be rotated from 0° to 90° around two relatively perpendicular axes – in other words, a horizontal and vertical axis. The rudder's two-dimensional rotation gives the robot the potential to adapt to flows from various directions.

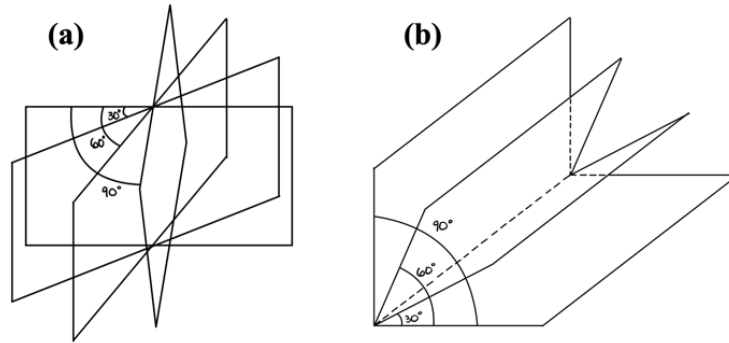

Fig. 2. Examples of the rudder rotated by 0°, 30°, 60°, and 90° (a) horizontally or (b) vertically.

As the robot walks, the flow that is in the same direction as the robot will exert a pushing force. Meanwhile, the flow from the opposite direction will exert a resisting force. The robot adapts to flows by using the rudder to find the optimal balance between these two opposing forces that helps it travel fastest with or against flows. Side forces have a smaller impact as it is perpendicular to the direction of motion.

The rudder is controlled by a two-servo mechanism. The usage of a servo allows the robot to rotate the rudder with precision. The rudder is fastened to the top of the servo mount, which is connected to a horizontally attached lowering servo that controls the rudder's vertical rotation. Note that the incident angle is equal to the rudder's rotational degree. The incident angle is maximized when the rudder is rotated upwards at 90°, perpendicular to the ground and water flow. The maximized incident angle maximizes both resistance and push force. The lowering servo can lower the board until it is nearly parallel to the baseboard – at 0 degrees vertically. In such a form, the incident angle is minimized, which minimizes the resisting force when walking against the flow. The vertically-attached turning servo controls the rudder's horizontal rotation. By adjusting the rudder's rotation and, thus, the incident angle, the servos help the robot adapt to the flows.

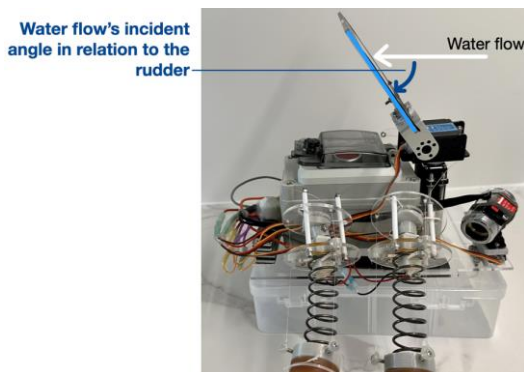

Fig. 3. The incident angle of the water flow in relation to the rudder's surface when the two come in contact.

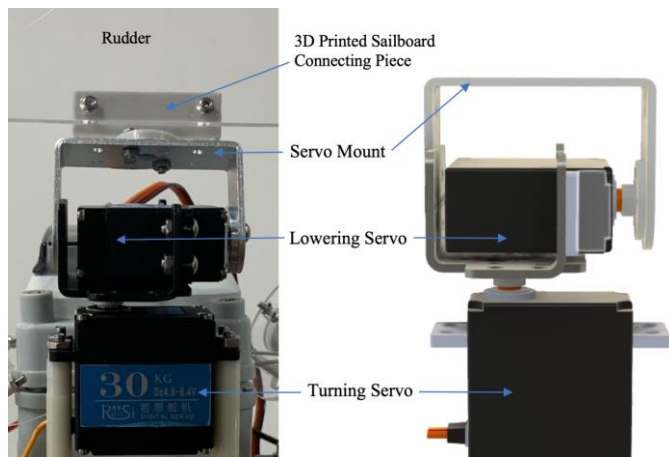

Fig. 4. The two-servo mechanism that controls the rudder.

**B. Spring Robot Legs**

The spring leg will be manipulated by three strings evenly spaced out around the outer rim of the legs. Inspired by marionettes – which are puppets controlled from above by strings attached to their limbs – the legs are bent in different directions depending on which string is pulled on.

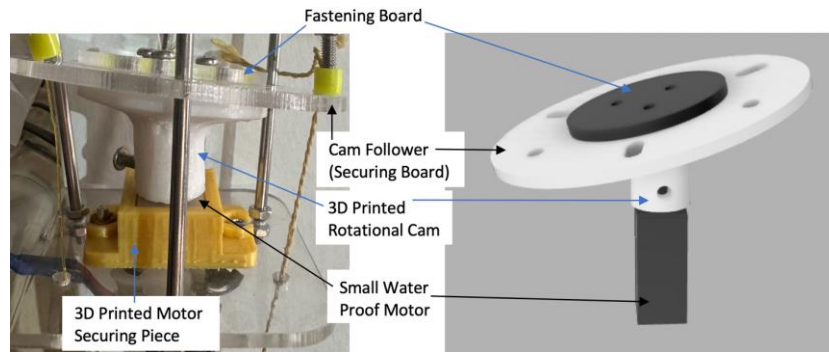

Fig. 5. Labeled components of the cam and follower mechanism.

The cam and follower mechanism is used to automate the pulling of the strings by translating the rotational motion of the motor into a linear up-and-down motion of the strings. To clarify, this mechanism consists of a cam follower at the top, a custom-designed 3D printed cam in the middle, of which the top platform is designed at a 25-degree slant, and a small waterproof vertical motor. One end of each string passes through the cam follower and is fastened at the top. The top of the cam is connected to the follower at a 25-degree slant, and a vertical motor shaft passes through the bottom half of the cam. As the motor shaft rotates, the cam rotates in the same way. However, the follower does not need to rotate. Therefore, rather than being fixed onto the cam, the follower is clamped in between the cam and the fastening board. Three screws on the fastening board penetrate the cam follower – without fixing it in place – and into the rotational cam. To further ensure that the follower does not rotate, three axles restrict the horizontal motion of the follower.

Meanwhile, the cam's 25-degree slant allows certain parts of the follower to rise while the opposite side is lowered. In short, as the motor and rotational cam rotate, the cam follower and thus the attached strings move only in a linear up-and-down motion. As one string is pulled, the others are gradually lowered. Two strings are primarily used to pull the legs in a back-and-forth movement, and a third to lift the leg up slightly when returning to the front so that the robot only pushes off the ground in one direction. The magnitude of the leg's rotational motion could be adjusted by the length of the string.

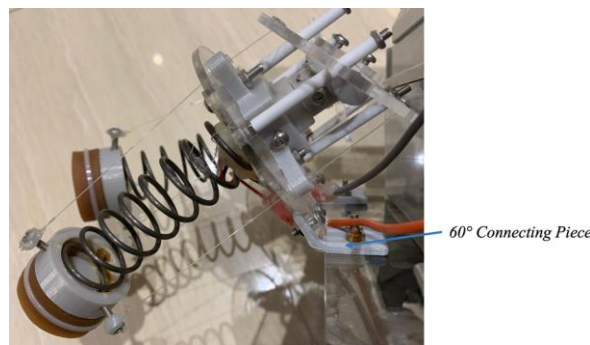

Fig. 6. One of four identical spring legs

Note that the legs are not designed to hold the robot up like pillars. On land, they just need to balance the robot and keep it barely above the ground because designing the legs to stand completely vertically causes the legs to rotate in a circular movement. The legs need to move in a primarily front and back movement in order for the robot to walk. The lift in the water will help the robot stand high enough to travel effectively.

### C. Self-adjust Rudder

The rudder robot has an additional feature: using a flow rate sensor, the robot determines whether it is facing towards or away from the water flow and self-adjusts the rudder to a preprogrammed optimal angle to travel fastest with or against flows. The flow rate sensor is programmed to record the flow rate from two directions: the front and the back. By comparing the flow rate of the two directions, the robot determines which direction the flow is coming from and automatically self-adjusts the rudder using the two-servo structure to a preprogrammed optimal position to help it travel faster with or against the flow.

III. EXPERIMENTS

A. Effectiveness of Rudder

The experiments will be conducted on a flat surface, in sanitized water, in a tub. An artificial flow generator will simulate the water flow. A meterstick and stopwatch are used to measure distance and time. There are two stages in the testing of the rudder robot. The first stage tests if rotating the rudder to seven different angles influences the robot’s travel speed when walking with or against the water flows. There are two experiments at this stage: one testing the rudder’s influences when the robot walks in the same direction as a 12,000 liters per hour water flow, and the second testing against the water flow. The independent variable is the seven rotation degrees of the rudder, which is also the incident angle (seven test groups): either horizontally or vertically rotated by 0°, 30°, 60°, or 90°. The rudder is in the same position when horizontally rotated by 90° and vertically rotated by 90°. The dependent variable is the seconds taken for the robot to travel a fixed distance. Important control variables included the flow rate, experimental environment, distance traveled by the robot, and water depth (60 cm deep). The second experiment has the same variables except that the robot travels against the water flow. The travel speeds are computed by traveled dividing distance over time lapsed.

B. Automation of Flow Adaptation

The second stage of the experiment tests if the robot can determine if its front or back is facing the water flow and correctly self-adjust its rudder to the optimal angle. Similarly, there will be two experiments: facing toward the flow and facing away. Each test group will contain 20 trials, and the rudder would be initialized to a random angle. Successful trials are tallied. Important control variables include the distance between the flow generator and the robot (60 cm) and the flow rate (12,000 L/H).

IV. RESULTS AND DISCUSSION

A. Effectiveness of Rotating the Rudder

Note that the incident angle is equal to the rudder’s rotational angle.

Table 1. Average Time Taken by the Robot to Travel in the Same Direction as the Flow with Rotated Rudder

	Travel Distance	Horizontally Rotated				Vertically Rotated			
		0°	30°	60°	90°	0°	30°	60°	90°
Time Taken (seconds)	30 cm	3.86	3.84	3.42	2.34	3.86	3.47	2.55	2.34
	40 cm	5.19	4.98	4.49	2.96	5.14	4.40	3.55	2.96
	50 cm	5.90	5.81	5.42	4.84	5.51	5.43	5.21	4.84
	60 cm	6.65	6.94	6.55	6.00	6.02	6.05	6.78	6.00

When walking in the same direction as the water flow, the robot travels faster – uses less time – as the rudder rotates more and the incident angle increases. To compare, the robot traveled fastest when the board was rotated by 90°, being perpendicular to the flows. The robot's average speed at this position is 0.11 meters per second, whereas when the rudder was rotated by 0° vertically, the robot's speed was around 0.09 meters per second. Therefore, the results show that the robot can travel up to 37% with its rudder perpendicular to the flow compared to its other rotations.

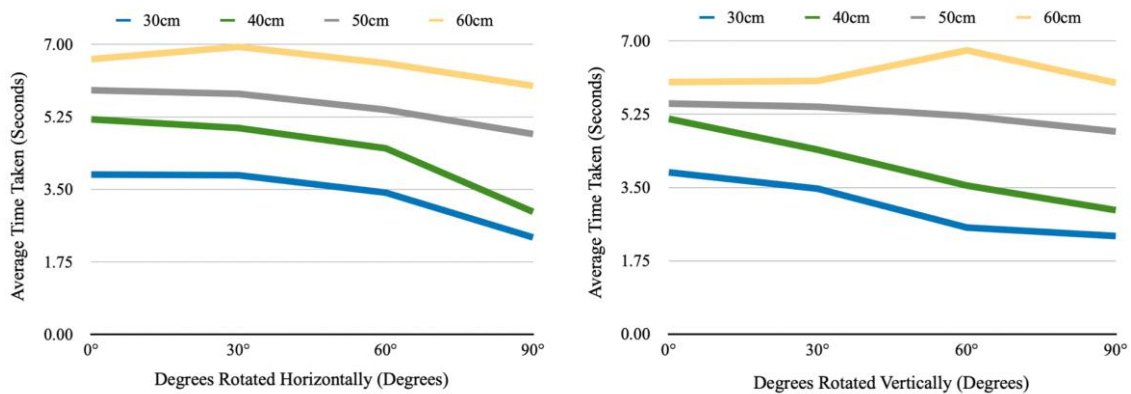

Fig. 7. Average Time Taken for Robot to 30,40,50 and 60 cm With the Flow with Rudder Horizontally (left) or Vertically (right) Rotated to Various Degrees

Table 2. Average Time Taken by the Robot to Travel Against the Flow with Rotated Rudder

	Travel Distance	Horizontally Rotated				Vertically Rotated			
		0°	30°	60°	90°	0°	30°	60°	90°
Time Taken (seconds)	30 cm	4.38	4.58	4.87	5.13	2.95	2.96	4.51	5.13
	40 cm	6.18	6.47	6.45	7.41	3.98	4.35	6.38	7.41
	50 cm	7.72	8.11	8.51	9.34	5.61	5.88	8.53	9.34
	60 cm	10.27	11.35	11.04	12.22	7.50	8.23	11.43	12.22

When walking against water flows, the robot takes longer to travel a fixed distance as the rudder’s rotation increased. Therefore, when walking against flows, the rudder robot travels faster with a smaller incident angle. To compare, the robot traveled fastest when the rudder was vertically rotated by 0°, parallel to the flow direction. The robot’s average speed at this position is 0.09 meters per second. When rotated by 90°, the robot’s speed was around 0.05 meters per second. Therefore, the results show that the robot can travel up to 80% faster by lowering the rudder when compared to its other forms.

Through observation, the increase in the incident angle increases both the resisting force as well as the pushing force exerted by the water flow on the vehicle. However, as long as the water flow is pushing the robot forward, the pushing force will be greater than the resisting force. Therefore, when the robot walks with the water flow, it will ultimately accelerate forward even if the rudder increased the resisting force.

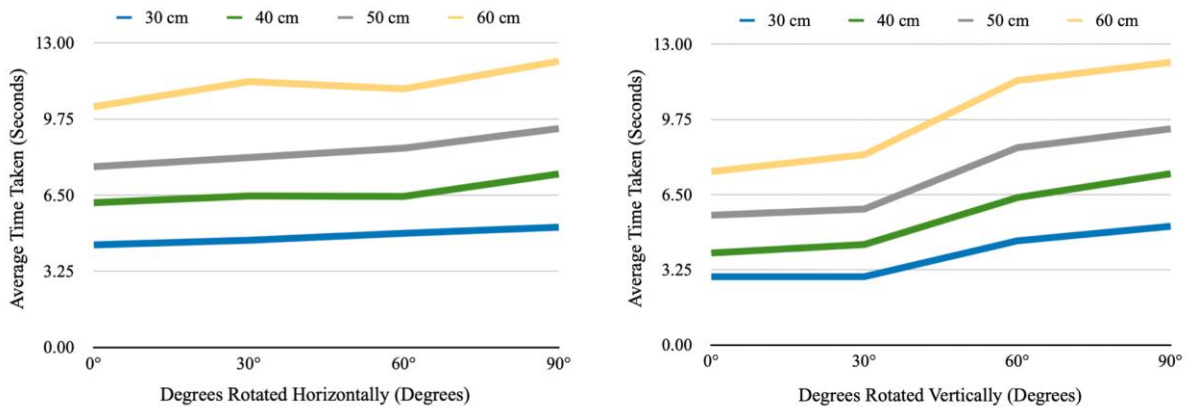

Fig. 8. Average Time Taken for Robot to 30,40,50 and 60 cm Against the Flow with Rudder Horizontally (left) or Vertically (right) Rotated to Various Degrees

Table 3. Average Speed of the Robot When Travelling With or Against Flows with Rotated Rudder

		Horizontally Rotated				Vertically Rotated			
		0°	30°	60°	90°	0°	30°	60°	90°
Average Speed (m/s)	With Flows	0.08	0.08	0.09	0.11	0.09	0.09	0.10	0.11
	Against Flows	0.06	0.06	0.06	0.05	0.09	0.08	0.06	0.05

**B. Successfulness to Self-adjust Rudder**

Table 4. Successfulness of the Robot’s Ability to Correctly Self-adjust the Rudder

	Travel Against Flows (Facing Towards Flow)	Travel with Flows (Facing Away from Flow)
Successful Trials (out of 20)	12	16
Success Rate	60%	80%

For the second stage of the experiment that tested the robot’s autonomy when self-adjusting its rudder to the optimal angle, the robot successfully used the flow rate sensor to determine whether its front or back is facing the water flow and correctly self-adjusted the rudder to the preprogrammed optimal angle 60% of the time facing towards the flow and 80% of the time when facing away.

### C. Discussion

The experiment results show that the proposed rudder robot can increase its travel speed when traveling with or against water flows by self-adjusting its rudder to a preprogrammed position. To specify, the robot travels fastest with the flow if the rudder is perpendicular to the flow, and fastest against the flow if the rudder is parallel to the flow. The robot can minimize the energy expended when using the least time to travel the fixed distance. Therefore, the rudder robot can quickly adapt to water flows and optimize its energy consumption by determining the direction of the flow and self-adjusting its rudder's rotation accordingly.

Though the rudder is stiff and requires more space, it is controlled by two servos, so it can easily rotate horizontally and vertically by any degree between 0° to 90°, even until 180° if necessary, increasing the robot's flexibility when adapting to the surrounding environmental conditions.

A few future research directions could be to test the rudder's influence in sideway or diagonal flows or on soft surfaces (like on sand or mud) or how the rudder concept could benefit other types of underwater vehicles, like thruster or swimming ROVs. A buoyancy tank could also be installed onto the vehicle to further help with remaining stable or adapting to water flows.

### V. CONCLUSION

The rudder robot can quickly self-adjust its rudder to adapt to the water flows, whereas typical thruster ROVs need to constantly readjust their position using multiple thrusters. Therefore, by using a different approach to respond to water flows, the rudder robot has an additional focus on optimizing energy consumption compared to common ROVs.

The modular design of the rudder robot also allows it to be easily scaled, especially the rudder concept. The rudder can be replaced with boards of different shapes and sizes. Compared to many biomimetic robots, the scalability of the rudder robot allows it to be conveniently deployed in various environments, such as sewage and riverbeds while carrying microplastic cleanup tools. The rudder may be transferred onto a different robot.

The results support the hypothesis that the robot can rotate its top-mounted, two-axis rudder to travel faster with or against the water flow, and therefore minimize its energy consumption. The vehicle can cover greater distances with less time and energy, assist in microplastic cleanup and hazard assessment for extended periods, and remain stable during underwater missions. It can help make underwater processes less human dependent and more efficient.

During microplastic cleanups, the rudder robot could quickly self-adjust its rudder to travel faster with or against the water flows. Optimized energy consumption also allows the robot to be powered by an onboard battery, making it more environmentally friendly and cheaper.

### REFERENCES

- [1] R. Cho, "How Do We Clean Up All That Ocean Plastic?," Oct. 2022.
- [2] United Nations. (n.d.). "Goal 14: Conserve and sustainably use the oceans, seas and marine resources." <https://www.un.org/sustainabledevelopment/oceans/>
- [3] Woods Hole Oceanographic Institution. (n.d.). "Marine Microplastics."
- [4] ZeBiotante, "10 Sources of Microplastics You Are Not Aware of," 2019.
- [5] N. DeRoberts, "Washing Laundry May Be An Underappreciated Source of Microplastic Pollution," Aug. 2019.
- [6] A. Matei, "Magnets, vacuums and tiny nets: the new fight against microplastics," *The Guardian*, Feb. 2021.
- [7] S. Ceurstemont, "How robots and bubbles could soon help clean up underwater litter | Research and Innovation."
- [8] "ROV Systems for First Responders | VideoRay," Sept. 2022.
- [9] T. Salumae and M. Kruusmaa, "Flow-relative control of an underwater robot," *Royal Society of London Proceedings Series A*, vol. 469, pp. 20671–, 03 2013.
- [10] M. Santhakumar and T. Asokan, "Power efficient dynamic station keeping control of a flat-fish type autonomous underwater vehicle through design modifications of thruster configuration," *Ocean Engineering*, vol. 58, pp. 11–21, 2013.
- [11] M. Ishida, D. Drotman, B. Shih, M. Hermes, M. Luhar, and M. T. Tolley, "Morphing structure for changing hydrodynamic characteristics of a soft underwater walking robot," *IEEE Robotics and Automation Letters*, vol. 4, no. 4, pp. 4163–4169, 2019.
- [12] B.-H. Jun, P.-M. Lee, and Y.-h. Jung, "Experience on underwater artifact search using underwater walking robot crabster cr200," in *OCEANS 2015 - MTS/IEEE Washington*, pp. 1–5, 2015.
- [13] J. Kinsey, R. Eustice, and L. Whitcomb, "A survey of underwater vehicle navigation: Recent advances and new challenges," 01 2006.
- [14] G. Dudek, P. Giguere, C. Prahacs, S. Saunderson, J. Sattar, L.-a. Torres-Mendez, M. Jenkin, A. German, A. Hogue, A. Ripsman, J. Zacher, E. Milios, H. Liu, P. Zhang, M. Buehler, and C. Georgiades, "Aqua: An amphibious autonomous robot," *Computer*, vol. 40, no. 1, pp. 46–53, 2007.
- [15] M. Chellapurath, K. L. Walker, E. Donato, G. Picardi, S. Stefanni, C. Laschi, F. Giorgio-Serchi, and M. Calisti, "Analysis of station keeping performance of an underwater legged robot," *IEEE/ASME Transactions on Mechatronics*, vol. 27, no. 5, pp. 3730–3741, 2022.