

Management Stepper of 3d - Printer

Batyrkanov Zhenish I¹, Kadyrkulova Kyial K², Belialov Shaibek A³

¹Professor, Doctor of Technical Science, Kyrgyz Technical University named after I.Razzakov, 66 Mira Avenue, Bishkek, 720044, Kyrgyz Republic,

²senior teacher, Kyrgyz Technical University named after I.Razzakov, 66 Mira Avenue, Bishkek, 720044, Kyrgyz Republic

³post-graduate student, Kyrgyz Technical University named after I.Razzakov, 66 Mira Avenue, Bishkek, 720044, Kyrgyz Republic

ABSTRACT

We consider and resolved the problem of constructing the control algorithms to implement the movement of the workers of 3D- printer prescribed spatial trajectory. Due to the prevalence of stepper motors (SM) in 3D- printers, in article is reviewed the technique of algorithms synthesis for actuators control with SM. The prescribed trajectory in this work is given by the tabular method, on the basis of job control points applied to spatial models manufactured parts. It is obvious that the greater the number of reference points will be taken, the better will be reproduced form of detail at the 3D- printer. The paper presents original mathematical model of the SD as a controlled object. On the basis of the mathematical model and the table of prescribed movements is determined algorithm of SM control. Authors are reviewed technical realization questions of the synthesized control algorithm, given the structural and functional schemes and principal electrical schemes of functional elements. Also are analyzed the problems of SM positioning errors, as well as SD angular velocity choice questions.

Keywords: 3D-printer, stepper motor, stepper drive, the prescribed spatial trajectory, movement control, single step, driver, number of phases

Date of Submission: 25 October 2016



Date of Accepted: 22 November 2016

I. INTRODUCTION

The use of devices for rapid prototyping (known as 3D-printers), allows you to turn designed in 3D-model real-world objects in CAD-systems. Such devices allow get a prototype in development "material form" in a short time and at low cost. Application of 3D-printers can save a considerable amount of time and money during the development phase as compared with use for prototyping a specially designed tooling, machining and so on. At this point, she RP-technology (rapid prototyping) has developed to such an extent that prototypes in their physical properties are close to the objects (objects), created using traditional techniques.

In the design and development of 3D-printers, particularly important place is occupied with questions of development of drive control systems of working bodies of 3D-printers. To date, as many wires of 3D-printers types used drives built on the stepper motors (SM). The control system must provide, in the end, the feasibility of movement of working bodies of 3D-printers for a predetermined prescribed trajectory movements. The trajectory of movement determined by the given geometric shapes and manufactured products. For the synthesis of the required drive motion control algorithms for prescribed programs (paths) in the first place requires a mathematical model of the dynamics of a stepper motor, a control object. As far as we know, in the description of commercially available of 3D-printers, a mathematical model of the information is not given (silenced). And besides, are not given in the open information about specific control algorithms stepper drives. In connection with the foregoing, the aim of this work were as follows: for of 3D-printers using the method of fusing layering (FDM) to develop a method for the synthesis of control algorithms to implement the movement of stepper drives on the prescribed program.

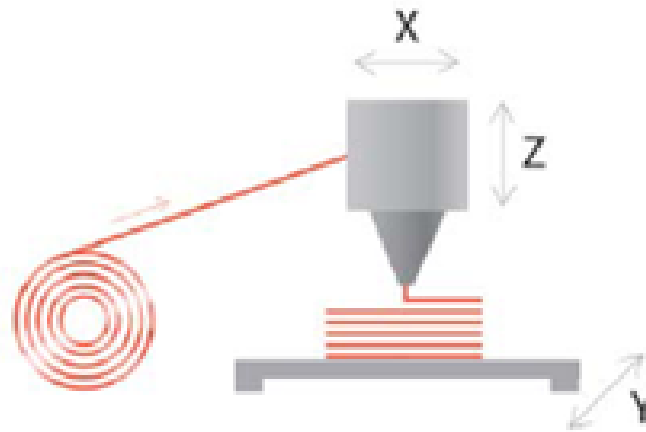

Fig. 1. Simplified model 3D- printer employing layered fusing method (FDM)

Development of mathematical models of the dynamics of SM as a control object.

First of all, we give "basic" information about SM.

For all types of stepper motor with an electronic switch, voltage pulses are generated, which are fed to the control windings arranged on the stator SM. With each pulse allows the rotor turn at a certain angle depending on the stepper motor designs. Currently, the most widely used high-torque two-phase hybrid stepper motors with angular displacement $1.8^\circ / \text{step}$ (200 steps / rev) or $0.9^\circ / \text{step}$ (400 steps / rev) in the field of mechanical engineering.

The time act of rotation of the rotor is determined by the SD sequence, duty cycle and frequency of admission to his control pulses, as well as the type and design parameters of SM. The main such parameters are the following: the number of phases (the number of windings and the control circuit of the connection) - distinguish between single- and multi-phase motors; SD type - the active or passive rotor; single rotor pitch (angle of rotation of the rotor when applying a single pulse); rated supply voltage; rated torque, etc. Stepper motor control is provided with a special electronic control unit.

Because of the stepper motor to the questions they "play" of the rotor [3] during the rotation, are not relevant. But accuracy is important the rotor installed in another predetermined position, the speed of rotation (installation) of the rotor in this position, and so forth. Insufficient installation speed stepper motor in the process of 3D-printers can lead to errors in reproduction form (surface) items.

For the synthesis of control laws consider stepper motor with a gear transmission mechanism on the motor shaft. Through this mechanism, the rotational motion of the rotor motor is converted into linear motion mechanisms (in the long run - the printhead) 3D- printer.

Let a rotary stepper motor shaft is planted (set) gear with a radius R and the angular distance between the two teeth degrees $\Delta \alpha$, the angle of rotation of the rotor SD, under the action of a single pulse of degrees. In the future, you want to be represented in radians. Translation from degrees to radians by the following formula

$$\Delta \alpha [rad] = \frac{3.14 [pad] (\Delta \alpha [grad])}{180 [grad]} \quad (1)$$

The action of a single pulse to the stepper motor with its rotor planted on the gear shaft with the radius R , a single angular step of rotor rotation is converted into linear motion of the pinion by a distance equal to

$$L_u = \Delta \alpha \cdot R \quad (2)$$

where, $\Delta \alpha$ - step stepper motor rotor rotation when applying a single pulse (degrees); L_u - Size of the linear gear step by the action of a single pulse on SD.

Since the stepper motor steps are carried out at discrete points in time, the mathematical model (MM) SM, as a control object is described using a finite-difference expression

$$\varphi_{k+1} = \varphi_k + n_k (\Delta \alpha) \quad (3)$$

φ_k - current where the angular position of the rotor on the SD, t_k - th point of time; n_k - the number of control pulses applied to the stepper motor for the length of time $[t_k, t_{k+1}]$; φ_{k+1} - The angular position of the rotor in a stepper motor t_{k+1} - the first time.

Equation (3) is used when the required movement of working bodies of 3D-printers are described in the angular coordinates. However, in most cases, the necessary movements are described in linear coordinates. This is similar to (3), the following MM control movement of the working bodies of 3D-printers

$$\begin{cases} X_{k+1} = X_k + n_{kx} l_{ux} \\ Y_{k+1} = Y_k + n_{ky} l_{uy} \\ Z_{k+1} = Z_k + n_{kz} l_{uz} \end{cases} \quad (4)$$

Where, X_k, Y_k, Z_k - the current coordinates of the working bodies of the axes X, Y, Z of the printer in κ - time; $X_{k+1}, Y_{k+1}, Z_{k+1}$ - Coordinates of the working bodies of the axes X, Y, Z at a $(k + 1)$ time; n_{kx}, n_{ky}, n_{kz} - The number of pulses are applied to the stepper motor axes drives for a specified period of time; l_{ux}, l_{uy}, l_{uz} - The value of the working body of linear steps along the axes X, Y, Z of action of single pulses on the corresponding SD.

Synthesis stepper drive control algorithm on the basis of tabular given prescribed trajectory

Consider the problem when working bodies of 3D-printers (print head) perform movements according tabular representation of control points in the manufactured products.

To accomplish this task, the mathematical model of the dynamics of a stepper motor is provided in the form of (4).

Thus, in practical terms, stepper motor control problem is reduced to finding the number of control pulses n_{kx}, n_{ky}, n_{kz} from the formulas (4) and applying them to the appropriate length of time $[t_k, t_{k+1}]$ for the SD. The

values $X_{k+1}, Y_{k+1}, Z_{k+1}$ are taken from the table of prescribed (target) control points of the spatial trajectory of working bodies of 3D-printers (Table 1).

Illustration of the prescribed spatial trajectory movement of working bodies of 3D-printers with the help of Figure 2.

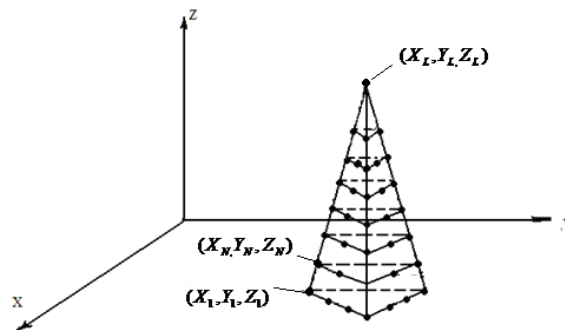

Fig. 2.Prostranstvennaya model parts coated with acontrol points.

According to the desired three-dimensional model of the object coated with a build test points table for the prescribed trajectory of the working body of the 3D- printer (Table 1).

Table 1

t_s	t_1	t_2	...	t_k	t_{k+1}	...	t_L	t_{L+1}
x_s	x_1	x_2	...	x_k	x_{k+1}	...	x_L	x_{L+1}
y_s	y_1	y_2	...	y_k	y_{k+1}	...	y_L	y_{L+1}
z_s	z_1	z_2	...	z_k	z_{k+1}	...	z_L	z_{L+1}

Start movement of the print head is carried out from the time t_1 and the initial position (X_1, Y_1, Z_1) . Then, the jump to the position (X_2, Y_2, Z_2) corresponding point in time t_2 . Further movement is carried out similarly and at the end of the first cycle corresponding to the "first layer" of the object being played, the print head comes to the initial position, (X_1, Y_1, Z_1) . From this position, a transition to the position (X_N, Y_N, Z_N) and then the movement is performed on the second layer of the object reproduced by 3-D printer. Further movement is performed on the third layer, etc. Thus, layers can be applied sequentially, each other. At the end of a transition to the end position (X_L, Y_L, Z_L) .

To determine l_{ux}, l_{uy}, l_{uz} the system (4) specific information need of the stepping motor and the gearbox shaft connected to the engine.

Taken DS4-6V SM brand and helical gear reducer with long screws 74mm diameter and 3 mm. This experimentally determined that for a single pulse helical gear reducer moves the load by 1.6 mm. so

$$l_{ux} = l_{uy} = l_{uz} = 1,6 \text{ MM}$$

Note that the number of required pulses counted by the formulas (4) to allow displacement given by Table 1, may lead to the fact that the calculated number of pulses (to be specific - by "X - axis")

$$n_k = (X_{k+1} - X_k) / l_u \quad (5)$$

It will not be expressed as an integer. In this case, it takes the nearest integer (the standard rules of rounding), and the maximum positioning error will be SD

$$l_{ux} = l_{uy} = l_{uz} = 1,6 \text{ MM} \quad (6)$$

Therefore, to reduce the error of positioning stepper motor must be reduced l_u . And this, in turn, reduce the step size of the unit (rotor rotation) $\Delta \alpha$, which is achieved by selecting a stepper motor the required number of poles (including - equivalent poles). The required speed stepper motor movement is achieved by reducing or increasing the value of the segment at the time $[t_k, t_{k+1}]$ - at a fixed number of pulses, which must be submitted to the SM for this segment. Reducing the length of time increases the speed of movement (movement) and SD, as a result, the print head.

Technical realization of the stepper motor control system for a prototype 3D- printer

The expediency of self-development and prototyping of 3D-printers is determined by the following circumstances: not all series being released 3D-printers are suitable for solving specific research problems - including because of the "closeness" of the software; the market value on the market of 3D-printers are still too high for their purchase to implement low-cost research projects, the educational process, etc.; itself to provide such a device is useful in terms of development of engineering skills of students and undergraduates, as well as the skills of their team work on projects with the division of roles.

Therefore, we present solutions for the model of the device, which is designed and used by the authors at the Department of "Automatic Control" KSTU named after I.Razzakova for educational purposes. It can be seen as a prototype 3D- printer.

To control the stepper motor using a computer (PC), where a pre-recorded information on all parameters of SM; table of prescribed movements working bodies of 3D-printers. The computer system of equations (4) and a predetermined value of time $[t_k, t_{k+1}]$ interval is performed by counting the required number of control pulses for supply to the stepper motor winding during each time interval.

Structural - functional stepper motor control system is shown in Figure 3. It includes such objects: LPT port (due to the traditional use of the LPT port for transmitting control pulses to the control unit and the corresponding ease of circuit solutions); control lines; controller; three electronic driver and stepper motor itself.

From LPT interface on the computer receives signals from the first four data buses to control the stepper motor windings of the motor; on three tires are transmitted control signals SM choice. These signals are sent to the controller. It happens the engine selection, which should work at a time - by submitting a sample of the signal on the corresponding channel stepper motor. Then, the control pulses are applied to the electronic driver - there are worse in the current and voltage. In the end, the converted pulses are transmitted to the respective winding stepper motor, which provides direct control of the engine operating condition.

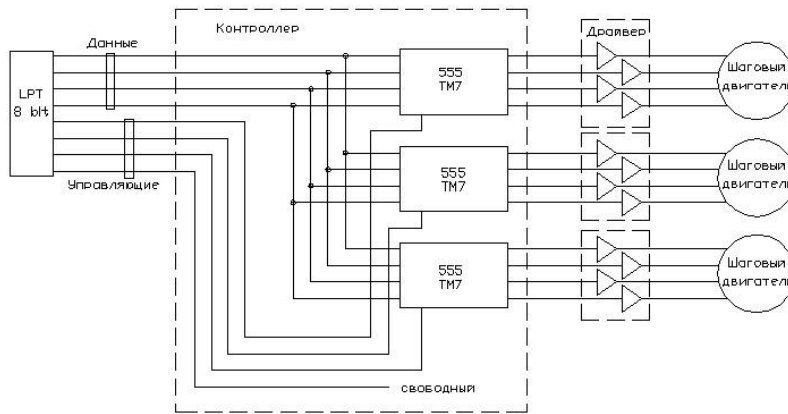

Fig. 3. Structural - functional diagram of a typical stepper motor control system.

The electric circuit of the controller is shown in Figure 4. SD Controller assembled on the three series chips 555TM7 (fairly common product that is included in the base elements of many CAD systems) and does not require firmware. Each chip has four D - trigger a latch mode. With the arrival of the control signals on the inputs D1-D4 are stored in flip-flops, but transferred to the chip outputs Q1- Q4 only when the arrival of the pulse at the inputs EI12 and EI34 latch. Thus, you can control the stepper motor driver a choice that should be involved in a particular time.

Note that currently using modern microprocessors and other possible circuit solutions. Stepper motor driver. For the described design, it is a four-channel amplifier or four keys (Fig. 4). Driver collected on four transistors CT 972 (also fairly common product). When a positive pulse at the base of the transistor is its opening at the same time providing the voltage to the motor winding. Diodes are needed to extinguish the self-induction electromotive force occurring in the windings, and a parallel filter (consisting of a resistor and a capacitor) is used to "cut" high-frequency components. The circuit is powered by a DC voltage of 12 volts. As a programming language to create a program that provides control of the layout work has been selected Pascal language in Delphi 7. C environment, the use of this language has developed a special program, there are about 600 lines of code and is intended for use on the control PC. Type of operating system used - is not critical. The peculiarity of the use of the program is that it works in real time. In this case the execution of lines of program code in parallel worked through the layout of 3D-printers.

We emphasize that the authors of this article do not set themselves the aim of developing a prototype device intended for mass industrial production. Therefore, the construction described above should be considered as a kind of base, which can be further modified in various ways - including and within the framework of the educational process.

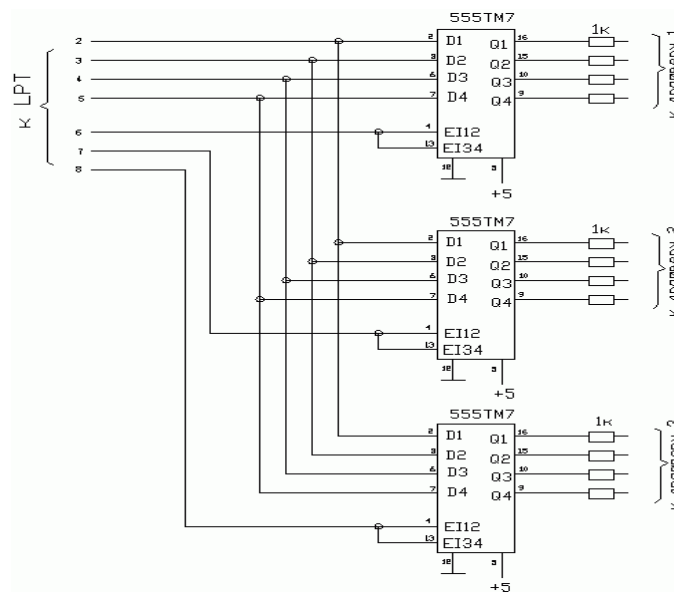

Fig. 4. A typical electrical circuit of the controller, used to control the stepper motor.

Figure 5 and Figure 6 shows part of the layout designed for the manufacture of that part of the decommissioned matrix printers were used. The ability to use these parts is particularly important for schools because they usually do not have a fleet of machine tools needed to make all the necessary components and units, and their order in the external organization requires a significant investment.

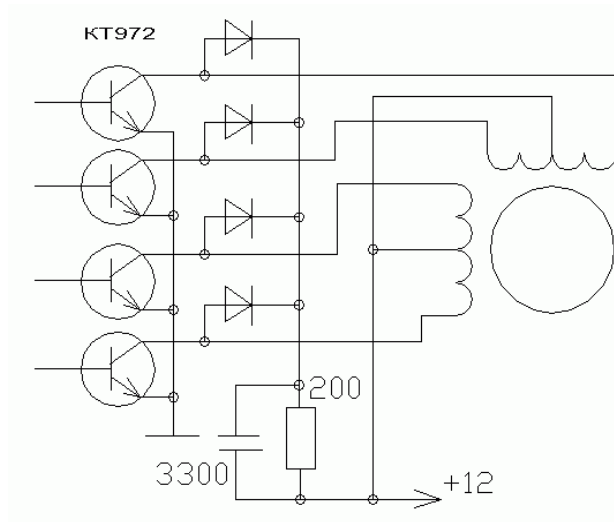

Fig.5. Stepper motor driver circuitry

II. CONCLUSIONS

1. Mathematical models of SD as a control object.
2. Consider the resolution of certain issues of technical implementation of the stepper drive control system.

REFERENCES

- [1]. Bolshakov V., Bochkov A. i.dr. Osnovy 3D - modelirovaniya. [Basesof 3D - modelling]/ Sankt- Peterburg 2012. 304p.
- [2]. Karpenko B.K., Larchenko V.I., ProkofevYu.A. Shagovyeelektrodvigateli – [Stepping electric motors] -Kiev: Izd-vo «Tekhnika», 1972. 216p.
- [3]. Aaron Council, Michael Petch.3D Printing: Rise of the Third Industrial Revolution, Publisher: gyges3d.com; 2014 edition, 2014.116p.
- [4]. Canessa E, Fonda C, Zennaro M. Low-cost 3D Printing for Science, Education and Sustainable Development, Publisher: ICTP—The Abdus Salam International Centre for Theoretical Physics 2013. 119p.
- [5]. Jacobs P.F. Rapid Prototyping and Manufacturing: Fundamentals of Stereolithography. - Publisher: Society of Manufacturing Engineers, 1992 . 434p.