

Research, Development Intelligent HVAC Control System Using Fuzzy Logic Controller

Konstantins Biktimirovs¹, Igors Uteshevs²

¹Riga Technical university, Latvia, Riga

²Riga Technical university, Latvia, Riga

ABSTRACT

The paper describes an automatic climate in offices, describes the principles of the automation equipment climate, considered air parameters described control algorithms were compared automation system PID-controller and using fuzzy logic controller is designed microclimate model in Matlab program with a fuzzy logic controller.

Keywords: conditioner, fuzzy logic, HVAC, Matlab, PID-regulator, ventilation

Date of Submission: 17 May 2016



Date of Accepted: 05 November 2016

I. INTRODUCTION

The introduction of the paper should explain the nature of the problem, previous work, purpose, and the contribution of the paper. The contents of each section may be provided to understand easily about the paper.

In recent years, the office market is experiencing rapid growth. There are new business centers, which are located in a variety of sizes of companies, from small to large companies. Because of this, in the office are continuously converted to adapt to customer requirements. Intense competition in the market of real estate for rent are forced building owners to create the most comfortable conditions for work with economical consumption of resources, where the main electricity consumers of heating, ventilation and air-conditioning. Electricity consumption in the developed countries of the building is 40% of total energy consumption, while the HVAC system energy consumption can be up to 50% of total energy consumption in buildings [[1],[2]].

Employees spend a lot of time at work, of which many jobs are office buildings. Therefore, it is important to provide a healthy, comfortable and productive working environment, the majority of the inhabitants of the buildings will be considered a pleasant and stimulating stay there and work. Selection of a heat source and cold source is one of the most important factors in determining the space stay in air parameters. Temperature is one of the most important factors of space environment that affect employee productivity. Air drying is necessary not only for reasons of comfort and health, but also to avoid a high relative humidity of the negative impact on the heating, ventilation and air conditioning (HVAC) [[1]].

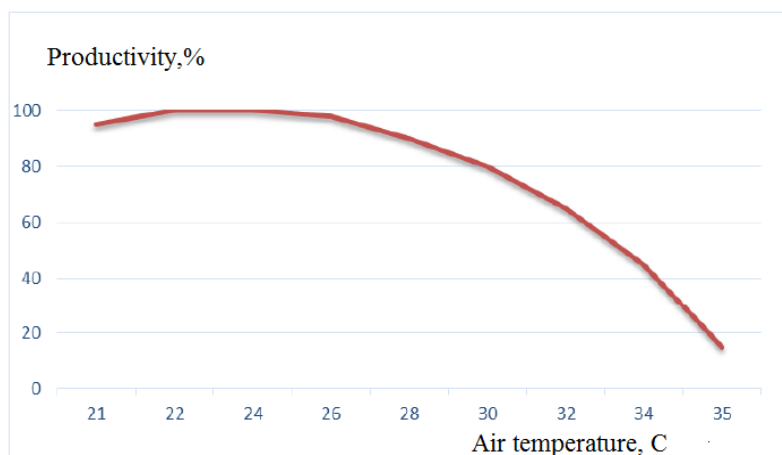

Figure 1. The dependence of productivity on the ambient temperature changes.

As you can see from the diagram, the indicator drop in efficiency is observed when the temperature rises over 26 C°.

II. PROBLEM FORMULATION

Climate room type can be divided into:

- The rooms in which the relative humidity range is limited by the maximum and minimum level. For example, public buildings, where the humidity level is determined by the requirements of the comfort of people.
- Areas that do not allow the condensation of water vapor on the surface. For example - hardware factories, media files, etc., where condensation may drop as a result of rapid changes of temperature.

Temperature adjustment for each individual air-conditioning unit allows the possibility of grouping of one room within the host computer to the controller control section is transmitted via a local control network.

The system is controlled from the local control panel, which is located in the central control computer. In the panels of local and central control computer displays the following information:

- Temperature of supply air ;
- Relative humidity of incoming air;
- The temperature of the circulating water heating radiator;
- Outside air temperature;
- Supply and exhaust fan air flow indication;
- Indication the status of the drive system.

On the local control panel, the central control computer is possible to set the following ventilation unit operating parameters:

- The required temperature;
- The minimum / maximum supply air temperature;
- Minimum heating radiator water temperature in winter;
- The minimum / maximum fan speed operation mode;

Conditioning technique used in quantitative and qualitative regulation. Quantitative adjustment caused the air condition is achieved by varying the air flow towards the permanent parameters. Quality control is used for multi-zone system. The process of air purification is shown in Fig. 2.

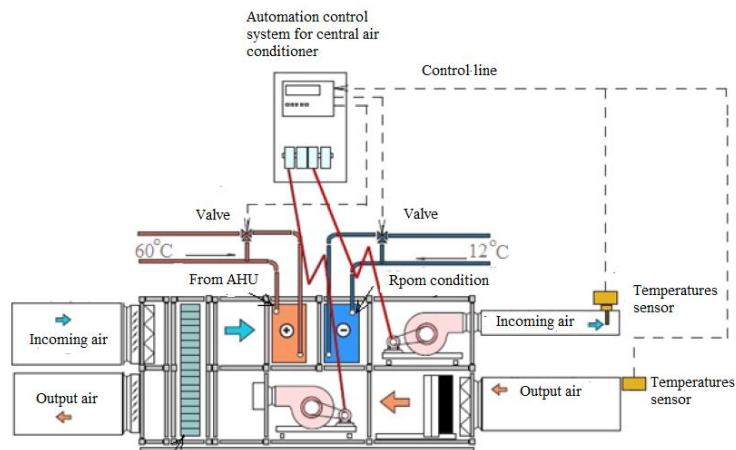

Figure 2. Automation control system for central air conditioner.

AHU (Air Handling Unit) is a regenerative heat exchange heater, chiller and automation of gates with management controllers. Given the AHU configuration year-round indoor maintain a certain temperature and humidity. The ventilation system commissioning and supply air temperature is delegated graph comparing correction and without correction (Fig. 3).

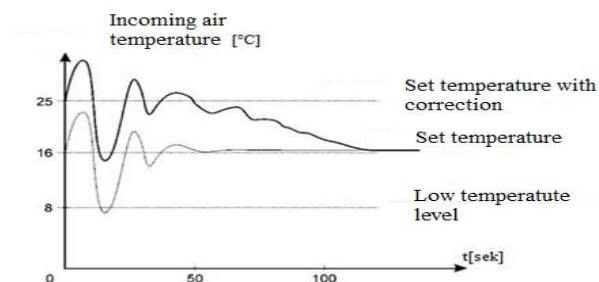

Figure 3. The ventilation system start air supply and temperature comparison diagram with and without correction

System objects are constantly reacting to perturbations controlled object, constant quality, optimal process of technological progress. Control algorithms executive, based on the analysis and control of information, parameters and processes to ensure the best process in accordance with the objectives of the production process. Thus, the safe, optimal control action algorithm development process helps to optimize the production process information flow.

The control object is shown in Fig. 4.

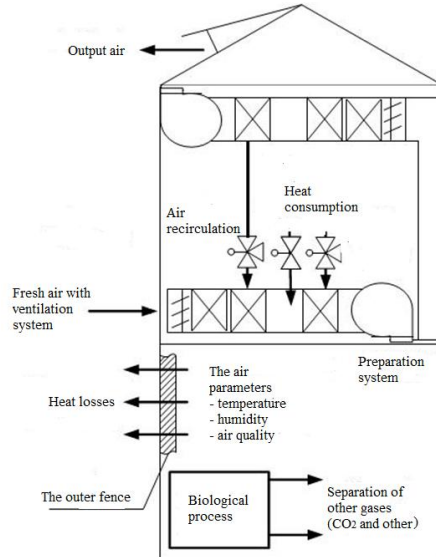

Figure 4. Control object with the microclimate

Rotation speed adjustment of supply and extract fan allows you to change the air exchange rate and thus allows to change the concentration of harmful impurities in indoor air. Chemical analysis of the composition of air in the room is to be mounted arranged in a system of four employers. Measurable values are carbon dioxide (CO_2), gas (CO) concentration, humidity and other harmful impurities. Fan operation may vary and depend on the appointment of functional and spatial dimensions. In this case, the system of governance structure of the PID controller base is very difficult, since the object is non-linear mathematical description, as well as requests to process at once some input signals. [[11]].

III. AUTOMATIC CONTROL SYSTEM

The objects, which is a non-linear mathematical description, as well as requests to process multiple input signals, can be successfully adjusted using Fuzzy Logic.

Indirect system rule base formation, first determine the input and output linguistic variables. Obviously, as one of the input linguistic variable quality of air temperature in the room should be used: T - "air temperature", while the second input linguistic variable quality " T_2 - rate of change of air temperature".

Linguistic Variable quality use mode switching regulator angle "cold" and air Conditioner "heat" [[12]].

Linguistic Variables - a figurative language that is commonly used control system engineers provided the logical spelling classical description of the algorithm.

Formula, when the air is hot and dry or cold and wet, it can be described in the language of Fuzzy Logic: comfort - (low temperature AND high humidity), OR (high temperature AND low humidity) (Fig. 5). There is a logical expression describes the human sense of space, with no forced air circulation.

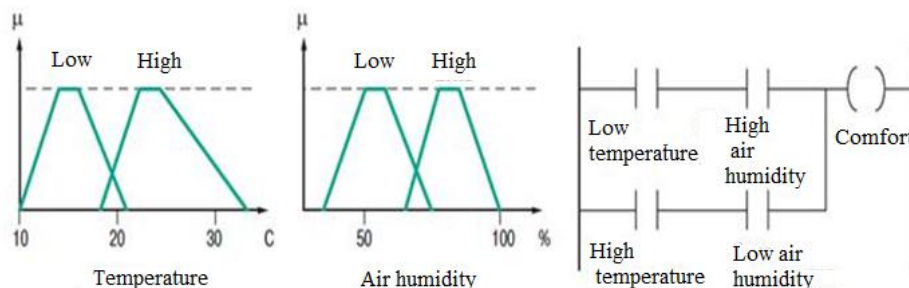

Figure 5. Linguistic Variables quality switching regulator angle "cold" and "heat"

As the quality and capacity increases means obscure logic to increase the competitiveness of the advantages of manufacturing companies in the technical-economic optimization of the search [[12]].

IV. FUZZY LOGIC MODELING IN MATHLAB

Fuzzy Logic modeling in Matlab environment occurs with Fuzzy Logic Toolbox extension pack use, which has been implemented in uncertain and ambiguous conclusion logic function. Fuzzy Logic blocks are manufactured in a clear signal transformation unclear in large quantities, but defuzzification transition of uncertain size meanings to certain physical parameters, which serves as Fuzzy Logic adaptive controllers (Fig. 6).

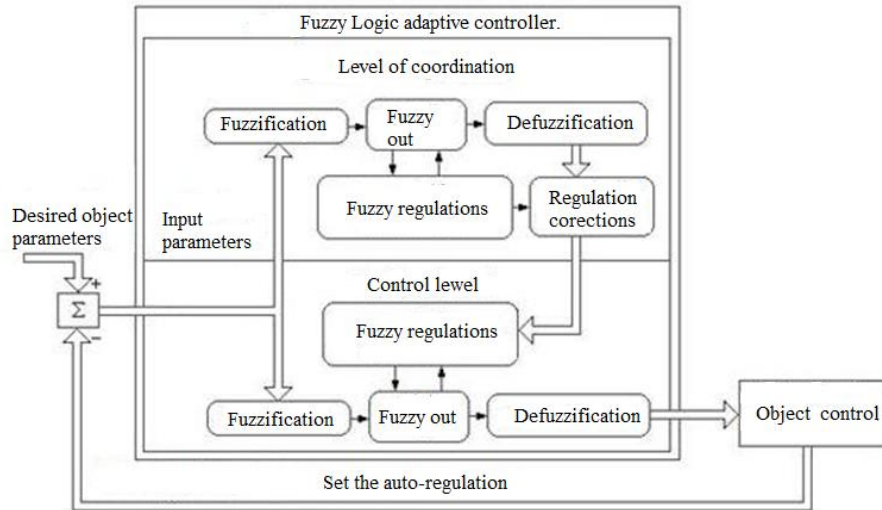

Figure 6. Fuzzy Logic adaptive controller.

With the HVAC system improvement in the control to the temperature and RH, which are designed for proportional (P) - the integral (I) - a derivative (D) PID control and sophisticated algorithms such as a lot of options, and combinations thereof, that are non-linear. Especially used in the control algorithm of HVAC systems are established for the PID. Therefore, the main purpose there is in it, to use an appropriate non-linear controllers and complex systems. In this case, Fuzzy Logic controllers to determine the dynamic mathematics HVAC system are using [[14]].

V. TEMPERATURE CONTROL SYSTEM PARAMETERS RELATIONSHIP CALCULATION

Is given dynamics changes calculation of temperature HVAC system. Other parameters of air - humidity, CO₂ content are calculated similarly.

External air temperature (a) The Importance Determined is the average annual temperature schedule technological space for a Specific geographic location. [[6],[12]]

$$W_{T1}(p) = \frac{T(p)}{T_a(p)} = \frac{1}{(T_T p + 1)} \quad (1)$$

Where:

$T(p)$ - Laplace for variable into temperature;

$T_a(p)$ - Laplace for variable out temperature;

T_T - time constant;

The transfers function of air temperature:

$$W_{T2}(p) = \frac{T(p)}{Qv_{const}(p)} = \frac{k_1}{(T_T p + 1)} \quad (2)$$

Where:

$T(p)$ - Laplace variable for into temperature;

$Qv_{const}(p)$ - Laplace variable for heating systems;

k_1 - activity coefficient;

$T_T p$ - time constant;

The relationship between air temperature changes $T(p)$ and fresh air for fresh consumption $G_{fresh}(p)$:

$$W_{T_3}(p) = \frac{T(p)}{G_{fresh}(p)} = \frac{k_2}{(T_T p + 1)} \tag{3}$$

Where:

- $T(p)$ - Laplace variable for into temperature;
- $G_{fresh}(p)$ - Laplace variable for fresh air consumption;
- K_2 - ventilation system activity coefficient;
- $T_T p$ - time constant;

VI. CLIMATE CONTROL SYSTEM DESIGN IN MATLAB MODEL WITH FUZZY LOGIC CONTROL

Climate control parameter using process is characterized by a number of links between the exit values and external influencing factors [[16],[17]].

Mathlab Simulink system with extension in Fuzzy Logic Toolbox packages.

Indirect logic operators are used in logical concept of a combination of an entry with an implied logic to calculate the real degree. It is used standard logical operators *AND*, *OR* and *NOT*.

Operator choice assumption degree T signs up as $\mu(T)$.

Crossing the amount of logical operators are *AND* operator. Real assumption degree "A AND B" is the minimum of real steps A and B: $\mu(A \text{ AND } B) = \min(\mu(A), \mu(B))$.

For example:

"Low temperature" is really to 0.7.

"Low humidity" is really to 0.5.

Therefore, the low temperature and low humidity "is true to 0.5 = MIN (0.7; 0.5). Using *AND* Fuzzy Logic result is similar to classical logic 0 and 1.

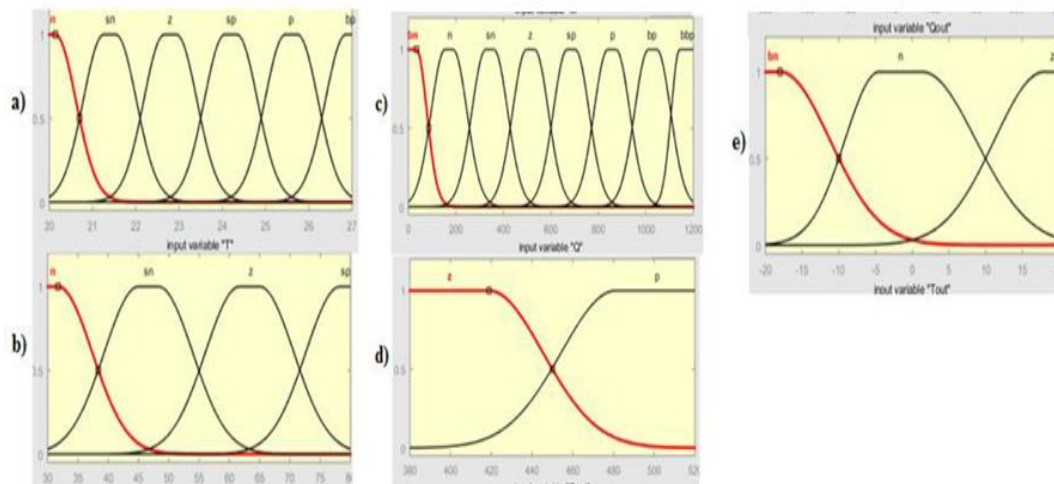

Figure 7. Transfer process diagram in the system: (a) - the outside temperature graph (b) - carbon dioxide external concentration graph (c) - temperature of the process timetable, (d) - humidity schedule, (e) - concentration of carbon dioxide graph shows.

Table 1: Terms and outgoing data variable Fuzzy Logic regulator output functions

Terms	«HeatValve», «VaporValve» un«AirValve»	
Close	-1	-1
Stop	0	0
Open	1	1

Fuzzy Logic Controller regulator is included in the model, the Fuzzy Logic Toolbox extension block in the form of Simulink packages.

Fuzzy Logic Controller regulator entrance signals of an external state of the environment: the external environment air temperature T_{out} and quote role in the external environment of carbon dioxide CO_2 concentration value.

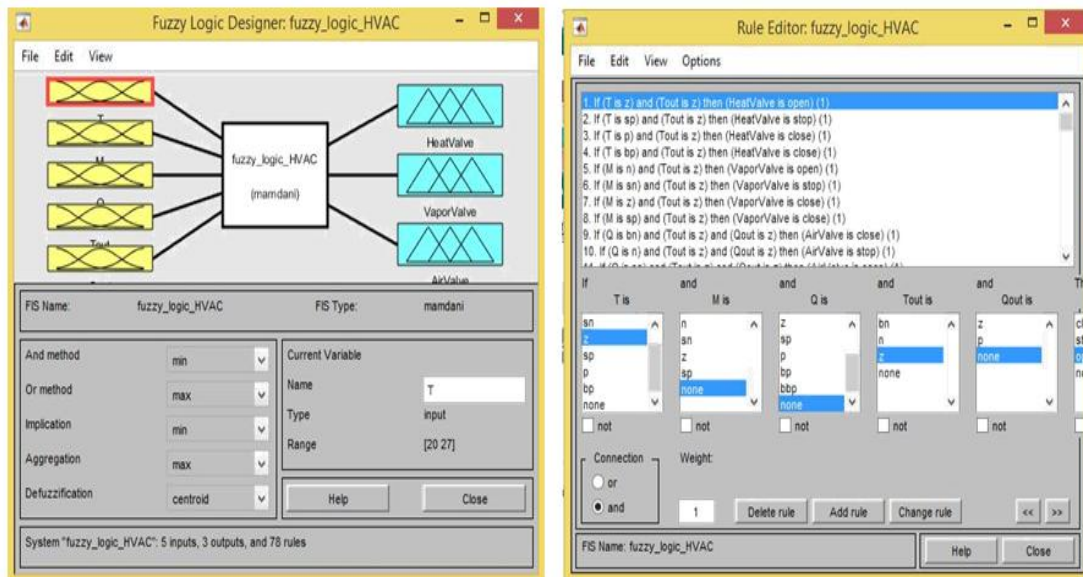

Figure 8. Intelligent Fuzzy Logic Controller in Simulink model of indirect regulatory structure as a technological process [[15]].

The Fuzzy Logic Regulator entrance signal of an external state of the environment: the external environment air temperature T_{out} and quote Role in the external environment of carbon dioxide CO_2 concentration value. Climate control Simulink environment with Fuzzy Logic Controller Model with indirect parameters (Fig. 9)

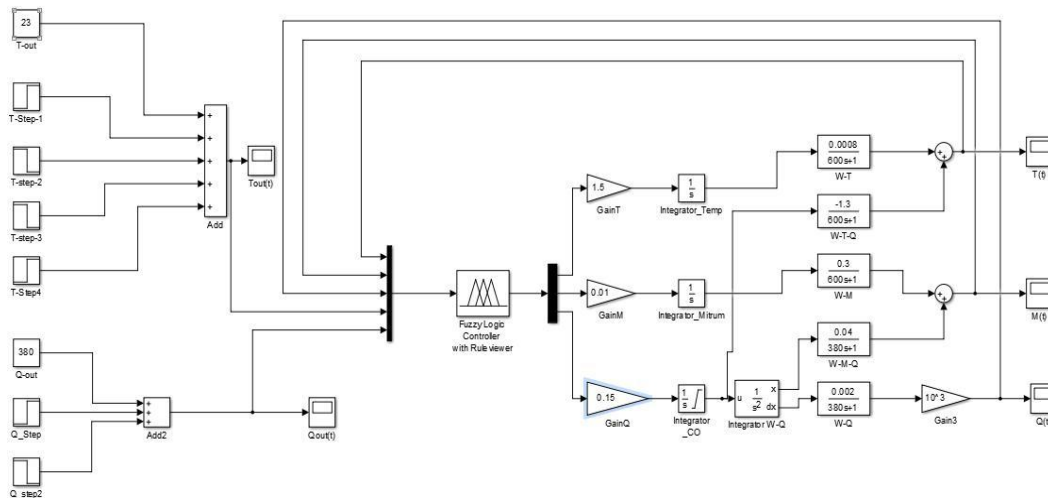

Figure 9. Climate control Simulink environment with Fuzzy Logic Controller

Fuzzy Logic regulator model has 2 input linguistic variables:

- T_{out} - external air temperature;
- Q_{out} - carbon dioxide content in the air, hosting the ventilation system.

VII. CONCLUSION

1. There is developed a climate model parameters, taking into account a number of probes the relationship between process parameters and control signals.
2. There is developed a model predictive control system to the process of fuzzy logic-based controller.
3. It is advisable to use the utility to control the parameters of automation with intelligent control technology based climate Fuzzy Logic Controller.
4. Temperature control set point "Fuzzy Logic" constantly chosen on the basis of the current temperature and humidity.
5. Defended the temperature in the room minimum tolerances thanks to lower energy use.

REFERENCES

- [1]. U. Peļīte. Gaisa kondicionēšana telpās ar kontrolējamu gaisa mitrumu. 24, 2006.
- [2]. A. Krumiņš. Ventilācijas sistemu vadības optimizācija. 25, 2008.
- [3]. A. Šnīders, P. Leščevics, A. Galiņš. Automātikas elementi un ierīces. 64, 2006.
- [4]. P. District. Building management system design and installations. 59, 2013.
- [5]. Tianyi, Z. Jili, S. Dexing Building and Environment. 34, 2011.
- [6]. О. Якорин. Современные системы кондиционирования воздуха. 269, 2003.
- [7]. Е. Белова. Кондиционирование воздуха в общественных зданиях. 2006.
- [8]. Building management system design and installation. 59, 2013.
- [9]. Д. Сибикин Отопления вентиляция и кондиционирование воздуха. 303, 2004.
- [10]. Е. Белова. Системы кондиционирования воздуха с чиллерами и фанкойлами. 435, 2003.
- [11]. М. Шведлер. Система, состоящая из нескольких чиллеров регулирование. 2000.
- [12]. А. Леоненко. Нечёткое моделирование в среде матлаб. 725, 2005.
- [13]. A new mathematical dynamic model for HVAC system components based on Matlab/Simulink International Journal of Innovative Technology and Exploring Engineering (IJTEE) Issue-2, July 2012.
- [14]. Application of the Fuzzy-logic Controller to the New Full Mathematic Dynamic Model of HVAC System International Journal of Engineering and Innovative Technology (IJETT) Volume 2, Issue 11, May 2013.
- [15]. <https://basegroup.ru/community/articles/fuzzylogic-math> 14.04.2016.
- [16]. A.Ukil. Intelligent Systems and Signal Processing in Power Engineering. 383, 2008.
- [17]. A Touati. Computers and Electronics in Agriculture. 450, 2013.
- [18]. А. С. Бондарь, В. А. Гордиенко. Автоматизация систем вентиляции и кондиционирования воздуха 548, 2005.
- [19]. http://www.nivey.ru/prom_cond_dlya_prom_pomescheniya_osobnosti.html.
- [20]. <http://likumi.lv/doc.php?id=225258> 27.03.2016.
- [21]. <http://vestnik.ispu.ru/sites/vestnik.ispu.ru/files/publications/str.70-73.pdf>.
- [22]. <https://basegroup.ru/community/articles/fuzzylogic-math> 14.04.2016.