

## Implementation of Bldc Motor Based Water Pump for Automotive Vehicle

<sup>1</sup>, Miss Pranoti S.Chaudhari, <sup>2</sup>, Girish K.Mahajan, <sup>3</sup>, Ajit P.Chaudhari  
<sup>1</sup>, PG Student

<sup>1, 2, 3</sup>, Department of Electrical Engineering, S.S.G.B.C.O.E &T, Bhusawal

---

### ABSTRACT

---

*In order to save resources and prevent global warming, there has been a present need in recent years to reduce the volume of CO2 emission and it improves the fuel consumption of automobiles. The trend in the automotive applications is to improve efficiency and to reduce volume and weight. Under these circumstances, the mechanical parts in the automobile industry are being replaced by electronics method. growing interest in energy efficiency. The trend in the automotive application is to improve fuel consumption, efficiency and to reduce volume and weight. Under these circumstances, the mechanical parts in the automobile industry are being replaced by electronic methods. Especially, to improve vehicle engine efficiency, power transmission and around the field of devices according to driving conditions need to be properly cooled. Conventional mechanical water pump is directly connected by the engine belt. For this reason, regardless of coolant circulation, the conventional mechanical water pump is always operated. The way which the mechanical water pump is replaced by electric water pump could reduce energy consumption. In this project, the implementation of the integrated BLDC drive for water pump system for automotive application is carried out This project investigates a promising approach for designing an electric water pump system consisting of a brushless machine combined with its electronic controller by using microcontroller programming. so I am going through hardware model.*

**KEYWORDS** – BLDC Motor, Microcontroller ARM7 processor, battery, water pump, Electric drive.

---

Date of Submission: 25-May-2015

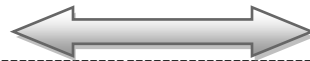

Date of Accepted: 08-June-2015

---

### I. INTRODUCTION

Interest has grown dramatically during recent years in the development of electrically-powered automotive accessories to replace conventional hydraulic and mechanically-powered equipment. This enthusiasm has been motivated by opportunities for significant energy savings and improved customer features. Nearly all accessory systems present in today's vehicles are candidates for electrical conversion. These include a variety of pumps, blowers, and actuators that can benefit from the introduction of variable-speed motor drives.

However, key barriers impeding the widespread introduction of such electric accessories include cost and reliability of the electrical equipment. cost remains the overriding challenge facing the developers of automotive electrical accessory equipment. An electric water pump was selected as the target accessory for this study because of its performance advantages and the opportunities it offers for achieving such an integrated package. Electric water pumps offer several advantages over conventional water pumps whose rotational speeds are always proportional to the engine speed .

These advantages include optimization of the engine's thermal performance by regulating the cooling water flow, the ability to continue cooling the engine after it has been turned off, and the elimination of a mechanical belt drive. The electric water pump concept is not new and has been used in some racing vehicles for years, where they are appealing means of eliminating belts and gaining extra horsepower from the engine. However, these commercially available electric pumps typically use dc commutator motors coupled to conventional centrifugal impeller pumps without taking advantage of integration opportunities.

DC motors have ever been prominent in various industrial applications because their characteristics and controls are simple. In an industrial point of view, the dc motor is still more than others at low power ratings. However, dc motor drives have bulky construction, low efficiency, low reliability and need of maintenance. Those features are unsuitable for automotive applications.

In recent years, the brushless dc (BLDC) motor is attracting growing attention for automotive applications. This is due to the total elimination of the brush/commutator assembly, which reduces audible noise and RFI problems. Moreover, BLDC motor has a number of advantages such as high efficiency, high power factor, and low maintenance cost. Newer units using brushless motors are beginning to appear on the market, while other advanced designs are in various stages of development by various automotive suppliers around the world. This project investigates a promising approach for designing an electric water pump system consisting of a brushless machine combined with its electronic controller by using ARM7 processor a hardware model implementation.

## II. BRIEF LITERATURE SURVEY



Fig.2. Brushless DC electric motor with floppy disk drive

The motor from a 3.5" floppy disk drive. The coils, arranged radially, are made from copper wire coated with blue insulation. The rotor (upper right) has been removed and turned upside-down. The grey ring inside its cup is a permanent magnet.[1]

Brushless DC electric motor (BLDC motors, BL motors) also known as electronically commutated motors (ECMs, EC motors) are synchronous motors that are powered by a DC electric source via an integrated inverter/switching power supply, which produces an AC electric signal to drive the motor. In this context, AC, alternating current, does not imply a sinusoidal waveform, but rather a bi-directional current with no restriction on waveform. Additional sensors and electronics control the inverter output amplitude and waveform (and therefore percent of DC bus usage/efficiency) and frequency (i.e. rotor speed).

The rotor part of a brushless motor is often a permanent magnet synchronous motor, but can also be a switched reluctance motor, or induction motor.

Brushless motors may be described as stepper motors; however, the term stepper motor tends to be used for motors that are designed specifically to be operated in a mode where they are frequently stopped with the rotor in a defined angular position. This page describes more general brushless motor principles, though there is overlap.

Two key performance parameters of brushless DC motors are the motor constants  $K_v$  and  $K_m$ .

### 2.1 Brushless vs. brushed motors

Brushed DC motors have been in commercial use since 1886. Brushless motors, on the other hand, did not become commercially viable until 1962.

Brushed DC motors develop a maximum torque when stationary, linearly decreasing as velocity increases. Some limitations of brushed motors can be overcome by brushless motors; they include higher efficiency and a lower susceptibility to mechanical wear. These benefits come at the cost of potentially less rugged, more complex, and more expensive control electronics.[1]

A typical brushless motor has permanent magnets which rotate around a fixed armature, eliminating problems associated with connecting current to the moving armature. An electronic controller replaces the brush/commutator assembly of the brushed DC motor, which continually switches the phase to the windings to keep the motor turning. The controller performs similar timed power distribution by using a solid-state circuit rather than the brush/commutator system.[3]

Brushless motors offer several advantages over brushed DC motors, including more torque per weight, more torque per watt (increased efficiency), increased reliability, reduced noise, longer lifetime (no brush and commutator erosion), elimination of ionizing sparks from the commutator, and overall reduction of electromagnetic interference (EMI). With no windings on the rotor, they are not subjected to centrifugal forces, and because the windings are supported by the housing, they can be cooled by conduction, requiring no airflow inside the motor for cooling. This in turn means that the motor's internals can be entirely enclosed and protected from dirt or other foreign matter.

Brushless motor commutation can be implemented in software using a microcontroller or microprocessor computer, or may alternatively be implemented in analogue hardware, or in digital firmware using an FPGA. Commutation with electronics instead of brushes allows for greater flexibility and capabilities not available with brushed DC motors, including speed limiting, "micro stepped" operation for slow and/or fine motion control, and a holding torque when stationary.

The maximum power that can be applied to a brushless motor is limited almost exclusively by heat; too much heat weakens the magnets and may damage the winding's insulation.

When converting electricity into mechanical power, brushless motors are more efficient than brushed motors. This improvement is largely due to the brushless motor's velocity being determined by the frequency at which the electricity is switched, not the voltage. Additional gains are due to the absence of brushes, which reduces mechanical energy loss due to friction. The enhanced efficiency is greatest in the no-load and low-load region of the motor's performance curve. Under high mechanical loads, brushless motors and high-quality brushed motors are comparable in efficiency.

Environments and requirements in which manufacturers use brushless-type DC motors include maintenance-free operation, high speeds, and operation where sparking is hazardous (i.e. explosive environments) or could affect electronically sensitive equipment.

## 2.2 Controller implementations

Because the controller must direct the rotor rotation, the controller requires some means of determining the rotor's orientation/position (relative to the stator coils.) Some designs use Hall effect sensors or a rotary encoder to directly measure the rotor's position. Others measure the back EMF in the undriven coils to infer the rotor position, eliminating the need for separate Hall effect sensors, and therefore are often called sensorless controllers.[6]

A typical controller contains 3 bi-directional outputs (i.e. frequency controlled three phase output), which are controlled by a logic circuit. Simple controllers employ comparators to determine when the output phase should be advanced, while more advanced controllers employ a microcontroller to manage acceleration, control speed and fine-tune efficiency.

Controllers that sense rotor position based on back-EMF have extra challenges in initiating motion because no back-EMF is produced when the rotor is stationary. This is usually accomplished by beginning rotation from an arbitrary phase, and then skipping to the correct phase if it is found to be wrong. This can cause the motor to run briefly backwards, adding even more complexity to the startup sequence. Other sensorless controllers are capable of measuring winding saturation caused by the position of the magnets to infer the rotor position.

## 2.3 Variations in construction

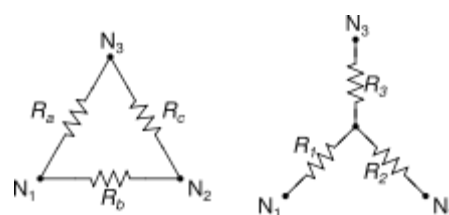

Fig.2.3.delta and wye winding

Schematic for delta and wye winding styles. (This image does not illustrate the motor's inductive and generator-like properties)

Brushless motors can be constructed in several different physical configurations: In the 'conventional' (also known as in runner) configuration, the permanent magnets are part of the rotor. Three stator windings surround the rotor. In the out runner (or external-rotor) configuration, the radial-relationship between the coils and magnets is reversed; the stator coils form the center (core) of the motor, while the permanent magnets spin within an overhanging rotor which surrounds the core. The flat or axial flux type, used where there are space or shape limitations, uses stator and rotor plates, mounted face to face. Out runners typically have more poles, set up in triplets to maintain the three groups of windings, and have a higher torque at low RPMs. In all brushless motors, the coils are stationary.[2]

There are two common electrical winding configurations; the delta configuration connects three windings to each other (series circuits) in a triangle-like circuit, and power is applied at each of the connections. The Wye (Y-shaped) configuration, sometimes called a star winding, connects all of the windings to a central point (parallel circuits) and power is applied to the remaining end of each winding.

A motor with windings in delta configuration gives low torque at low speed, but can give higher top speed. Wye configuration gives high torque at low speed, but not as high top speed.

Although efficiency is greatly affected by the motor's construction, the Wye winding is normally more efficient. In delta-connected windings, half voltage is applied across the windings adjacent to the driven lead (compared to the winding directly between the driven leads), increasing resistive losses. In addition, windings can allow high-frequency parasitic electrical currents to circulate entirely within the motor. A Wye-connected winding does not contain a closed loop in which parasitic currents can flow, preventing such losses.

From a controller standpoint, the two styles of windings are treated exactly the same.

## 2.4 Applications



Fig.2.4 four pole bldc motor

The four poles on the stator of a two-phase brushless motor. This is part of a computer cooling fan; the rotor has been removed [4].

Brushless motors fulfill many functions originally performed by brushed DC motors, but cost and control complexity prevents brushless motors from replacing brushed motors completely in the lowest-cost areas. Nevertheless, brushless motors have come to dominate many applications particularly devices such as computer hard drives and CD/DVD players. Small cooling fans in electronic equipment are powered exclusively by brushless motors. They can be found in cordless power tools where the increased efficiency of the motor leads to longer periods of use before the battery needs to be charged. Low speed, low power brushless motors are used in direct-drive turntables for gramophone records.

### 2.4.1 Transport

High power brushless motors are found in electric vehicles and hybrid vehicles. These motors are essentially AC synchronous motors with permanent magnet rotors.

The Segway Scooter and Vectrix Maxi-Scooter use brushless technology.

A number of electric bicycles use brushless motors that are sometimes built into the wheel hub itself, with the stator fixed solidly to the axle and the magnets attached to and rotating with the wheel.<sup>[8]</sup>

#### **2.4.2 Heating and ventilations**

There is a trend in the HVAC and refrigeration industries to use brushless motors instead of various types of AC motors. The most significant reason to switch to a brushless motor is the dramatic reduction in power required to operate them versus a typical AC motor. While shaded-pole and permanent split capacitor motors once dominated as the fan motor of choice, many fans are now run using a brushless motor. Some fans use brushless motors also in order to increase overall system efficiency.

In addition to the brushless motor's higher efficiency, certain HVAC systems (especially those featuring variable-speed and/or load modulation) use brushless motors because the built-in microprocessor allows for programmability, better control over airflow, and serial communication.

#### **2.4.3 Industrial engineering**

The application of brushless DC motors within industrial engineering primarily focuses on manufacturing engineering or industrial automation design. In manufacturing, brushless motors are primarily used for motion control, positioning or actuation systems.

Brushless motors are ideally suited for manufacturing applications because of their high power density, good speed-torque characteristics, high efficiency and wide speed ranges and low maintenance. The most common uses of brushless DC motors in industrial engineering are linear motors, servomotors, actuators for industrial robots, extruder drive motors and feed drives for CNC machine tools.

#### **2.4.4 Motion control systems**

Brushless motors are commonly used as pump, fan and spindle drives in adjustable or variable speed applications. They can develop high torque with good speed response. In addition, they can be easily automated for remote control. Due to their construction, they have good thermal characteristics and high energy efficiency. To obtain a variable speed response, brushless motors operate in an electromechanical system that includes an electronic motor controller and a rotor position feedback sensor.

Brushless dc motors are widely used as servomotors for machine tool servo drives. Servomotors are used for mechanical displacement, positioning or precision motion control. In the past DC stepper motors were used as servomotors; however, since they are operated with open loop control, they typically exhibit torque pulsations. Brushless dc motors are more suitable as servomotors since their precise motion is based upon a closed loop control system that provides tightly controlled and stable operation.

#### **2.4.5 Positioning and actuation systems**

Brushless motors are used in industrial positioning and actuation applications. For assembly robots, brushless stepper or servo motors are used to position a part for assembly or a tool for a manufacturing process, such as welding or painting. Brushless motors can also be used to drive linear actuators

Motors that directly produce linear motion are called linear motors. The advantage of linear motors is that they can produce linear motion without the need of a transmission system, such as a ball-and-lead screw, rack-and-pinion, cam, gears or belts, that would be necessary for rotary motors. Transmission systems are known to introduce less responsiveness and reduced accuracy. Direct drive, brushless DC linear motors consist of a slotted stator with magnetic teeth and a moving actuator, which has permanent magnets and coil windings. To obtain linear motion, a motor controller excites the coil windings in the actuator causing an interaction of the magnetic fields resulting in linear motion. Tubular linear motors are another form of linear motor design operated in a similar way.



#### 2.4.6 Model engineering

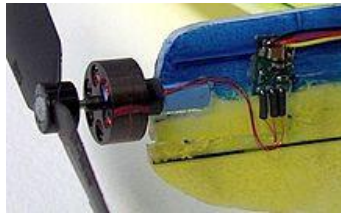

Fig.2.4.6 micro radio controlled airplane

A microprocessor-controlled BLDC motor powering a micro radio-controlled airplane. This external rotor motor weighs 5 grams, consumes approximately 11 watts and produces thrust of more than twice the weight of the plane.

Brushless motors are a popular motor choice for model aircraft including helicopters. Their favorable power-to-weight ratios and large range of available sizes, from under 5 gram to large motors rated at well into the kilowatt output range, have revolutionized the market for electric-powered model flight, displacing virtually all brushed electric motors. They have also encouraged a growth of simple, lightweight electric model aircraft, rather than the previous internal combustion engines powering larger and heavier models. The large power-to-weight ratio of modern batteries and brushless motors allows models to ascend vertically, rather than climb gradually. The low noise and lack of mess compared to small glow fuel internal combustion engines is another reason for their popularity.

Legal restrictions for the use of combustion engine driven model aircraft in some countries have also supported the shift to high-power electric systems.

#### 2.4.7 Radio controlled cars

Their popularity has also risen in the radio controlled car area. Brushless motors have been legal in North American RC car racing in accordance to ROAR since 2006. These motors provide a great amount of power to RC racers and, if paired with appropriate gearing and high-discharge Li-Po (lithium polymer) or considerably safer LiFePO<sub>4</sub> batteries, these cars can achieve speeds over 161 kilometres per hour (100 mph).

Brushless motors are capable of producing more torque and have a larger peak RPM compared to nitro or gasoline powered engines. Nitro engines climax to peak at around 46,800 RPM and 2.95HP, while a smaller brushless motor generally maximum torque start then tapering off can reach 50,000 RPM and 5HP.

#### 2.5 BLDC Motor Advantages:

Here is a basic breakdown of some of the primary advantages of the BLDC motor.

- High Speed Operation – A BLDC motor can operate at speeds above 10,000 rpm under loaded and unloaded conditions.
- Responsiveness & Quick Acceleration – Inner rotor Brushless DC motors have low rotor inertia, allowing them to accelerate, decelerate, and reverse direction quickly.
- High Power Density – BLDC motors have the highest running torque per cubic inch of any DC motor.
- High Reliability – BLDC motors do not have brushes, meaning they are more reliable and have life expectancies of over 10,000 hours. This results in fewer instances of replacement or repair and less down time for your project.

### III. PROBLEM FORMULATION: NEED AND SIGNIFICANCE OF PROPOSED RESEARCH WORK

Under these circumstances, the mechanical parts in the automobile industry are being replaced by electronic methods. Conventional mechanical water pump is directly connected by the engine belt. For this reason, regardless of coolant circulation, the conventional mechanical water pump is always operated.[5] In contrast, electric water pump is not directly connected and could operate at various speeds. The way which the mechanical water pump is replaced by electric water pump could reduce energy consumption. For this possible, integrated electric water pump is becoming more important. In recent years, the brushless dc (BLDC) motor is receiving more interest for automotive applications. This is due to the total elimination of the brush/commutator assembly, which reduces audible noise and RFI problems.[6]

For energy efficiency and small size, BLDC motor and drive are applied to the water pump. This project deals primarily with the implementation of the integrated drive for water pump for automotive applications. Experimental results from a laboratory prototype are presented to validate the feasibility of the proposed BLDC drive. The trend in the automotive application is to improve fuel consumption, efficiency and to reduce volume and weight. Under these circumstances, the mechanical parts in the automobile industry are being replaced by electronic methods. Especially, to improve vehicle engine efficiency, power transmission and around the field of devices according to driving conditions need to be properly cooled. Conventional mechanical water pump is directly connected by the engine belt. For this reason, regardless of coolant circulation, the conventional mechanical water pump is always operated. The way which the mechanical water pump is replaced by electric water pump could reduce energy consumption.[6]

**3.1 Proposed methodology during the tenure of the research / Planning of work**

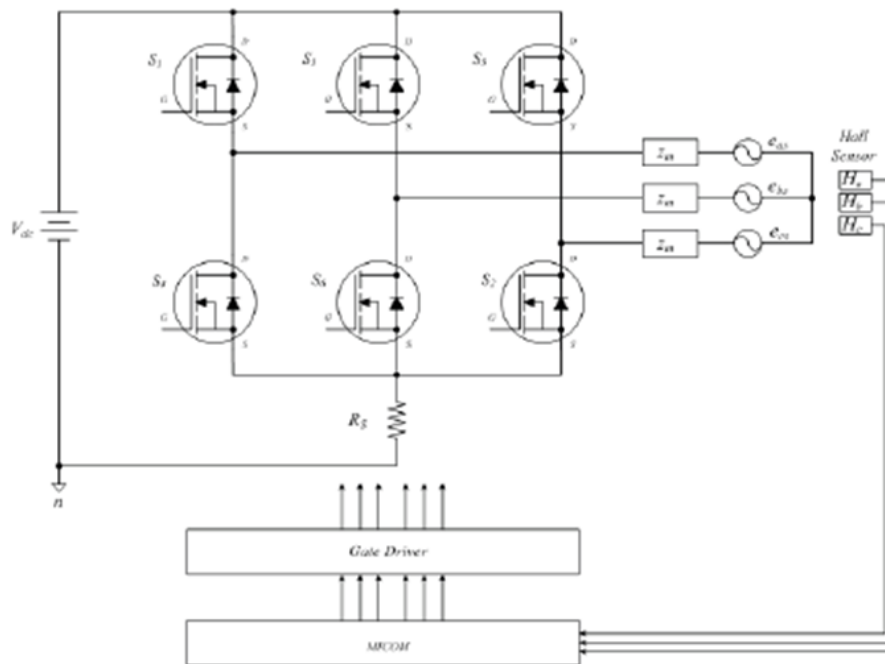

**3.2 Modeling of BLDC Motor Drive:**

The system will be battery operated and the processor arm7 or avr atmega16/32 can be used to design the bldc drive for the said pump application.system will consist of the hall sensor to sense the position of the rotor and the signal from this sensor is used to generate the proper sequence of the pulse to rotate the rotar in synchronism.

The three winding of the motor are used to provide the pulse through the MOSFET based bridge circuit designed as shown in fig above.[6]

Mosfet driver is fed the pulse from the controller and the driver drives gate of mosfet to conduct the voltage to the windings.

**3.2.1 Objectives**

1. Analysis the working and speed control of BLDC motor to be done. if it is working satisfactorily or not.
2. Analyze the application for the BLDC motor for Electric water pump for Automobile application based on its performance is studies and then the conclusion is drawn.[6]
3. The proposed work requires a model design and implementation and observe the performance to decide on the application for above discussed pump.[6]

**3.2.2 Expected outcome of the proposed work:**

Desing and construction of the complete bldc drive for the BLDC motor and attaching it to the water pump and testing the performance of the system under running condition test is carried out such as speed and load test.

#### **IV. CONCLUSION**

The importance of low cost and high reliability to the successful deployment of electrical accessories in future vehicles cannot be overstated. Careful attention to system optimization including the machine, converter, and load will always pay dividends in the development of new equipment. Electric water pumps offer several advantages. Among them, the efficiency is the main reason for electric water pumps. Conventional mechanical water pump is directly connected by the engine belt. For this reason, regardless of coolant circulation, the conventional mechanical water pump is always operated.

The way which the mechanical water pump is replaced by electric water pump could reduce energy consumption. Besides, electric vehicle (EV) do not have the internal combustion engine. The electric water pump is not directly connected and could operate at various speeds. This will result into Environmental and economical prospects give a fresh impetus to develop clean, efficient, and sustainable vehicles for urban transportation. Vehicle is the most popular means of transportation. This concept presents a design and implementation of BLDC motor drive for the automotive water pump. For the operation of a water pump for automobile application, it is important to consider not only performance but also reliability. In order to enhance reliability, all parts of the controller, which the operating temperature range is over 125 °C, was chosen. And for the cost, the drive was simplified.[6]

#### **V. ACKNOWLEDGEMENTS**

The authors would like to thank the Electrical Engineering Department Girish K . Mahajan , Ajit P. Chaudhari for permission to publish this work.

#### **REFERENCE:**

##### **Journal Papers:**

- [1]. Joon Sung Park!, Jun-Hyuk Choi!, Bon-Gwan Gu!, In-Soung Jung!, Senior Member, IEEE,1 Korea Electronics Technology Institute 203-101 Bucheon-TP BID, Yakdae-dong, Wonmi-gu,Bucheon-si, Gyeonggi-do, Korea, 420-140 Email:parlgs@keti.re.kr

##### **Books:**

- [2]. Iqbal Husain, Electric and Hybrid Vehicles, CRC Press, 2003.  
[3]. John M. Miller, Propulsion Systems for Hybrid Vehicles, IEE Power & Energy Series 4, 2004.

##### **Theses:**

- [4]. H. Hembach, SA Evans, and D. Gerling, "Systematic Comparison of BLDC Motors for Small Automotive Water Pump Applications,"ICEM, 2008, pp.1-5.  
[5]. Bon-Gwan Gu, Joon Sung Park, Jun-Hyuk Choi, In-Soung Jung "Development of BLDC Motor Drive for Automotive Water Pump Systems" Journal of International Council on Electrical Engineering Vol. 1, No. 4, pp. 395~399, 2011  
[6]. Jois K G1, B Aruna Rajan ,PG Student, EEE Dept, Hindustan University, Chennai ,Associate Professor, EEE Dept, Hindustan University, Chennai"Implementation of bldc motor drive for automotive water pump"  
[7]. IJREAT International Journal of Research in Engineering & Advanced Technology, Volume 1, Issue 1, March, 2013