

Bus Stand Lamp Using Piezoelectric Energy

¹M. N. M. Nasir, ²M. N. Aziz, ³Z. H. Bohari, ⁴H. I. Jaafar, ⁵Mohd Hafiz Jali,
M. K. Nor⁶,

Faculty of Electrical Engineering, Universiti Teknikal Malaysia Melaka, Hang Tuah Jaya, 76100, Durian
Tunggal Melaka

ABSTRACT

The development of piezoelectric energy harvester has rapidly becoming an attractive research in these few years mainly due to the largely use of semiconductor in power supply technology. Harvesting ambient vibration energy using piezoelectric element has become an interesting topic since the technology is using the free energy source, which can reduce a significant value in cost development. The prototype of bus stand lamp using piezoelectric energy was developed to show the concept of the harvester system. The objective of this product is to overcome the lacking lighting system problem for bus stand at rural place. By using the free energy source, which is gain from the people walking across this area, the piezoelectric disc was placed on the floor whereby the location of the piezoelectric disc is determined based on the maximum harvesting output power when people step on it. Power that harvested will then be stored in the super capacitor or battery before delivered to the load. The light emitting diode (LED) is used as the supply of the light to the bus stand since the energy efficiency of LED is higher compared to the traditional lighting. Two experiments were conducted to determine the maximum output of piezoelectric harvesting base which from the experimental results, it shows that a significant output voltage and current of 0.372A and 0.421A respectively is successfully generated which then can be use to charge the battery.

KEYWORDS: piezoelectric, super capacitor, harvester.

Date of Submission: 26 June 2014



Date of Publication: 10 July 2014

I. INTRODUCTION

Recently, research on alternative energy source that can provide power supply is increasing greatly as our technology is moving towards to the free energy source. The concept of implementing piezoelectric materials into the environment to provide a sustainable power source is drawing a lot of attention to the scientific community [1]. The ability of this material to harvest energy from vibration attracts people to do more research about the capability of this material to generate more energy. Piezoelectric material is used since it has several advantages such as their mechanical properties of being small, lightweight and versatility in endless array applications [2]. Lead zirconate-titanate (PZT) is the most commonly used for piezoelectric materials of power generation. PZT ceramic is suitable for energy harvesting systems since the efficiency of conversion from mechanical to electrical energy is controlled by the piezoelectric constants d and g . It is also have a high piezoelectric constant and high quality factor [4]. Scientifically, PZT form a tetragonal structure with a small atom in the center and when the crystal is strained, the center atom displaces from its lattice site and creates a potential [5].

Piezoelectric is an effect of the electromechanical relationship that allows certain materials such as crystals and synthetic ceramics to produce an output voltage power that come from mechanical stress or vibration. Piezoelectric elements are widely used in many applications such as acoustic transducers, mechanical actuator and for electric energy harvesting system. Ceramics (e.g. lead zirconate-titanate or PZT) and bimorph (e.g. polyvinylidene fluoride or PVDF) are also the common type of piezoelectric materials. The bimorph element material has its own advantages like being soft and flexible, but they have lower dielectric and piezoelectric constant than ceramics [3]. Most efficient materials are quite expensive.

For this project, cheaper materials such as ceramics disc that are less efficient, but will still work to demonstrate the concept of piezoelectric energy harvesting is used. The focus of this project is to develop a piezoelectric energy harvesting system, where the main design is to harness the vibration energy from walking people at bus stand and turn that wasted energy into electricity and supply power to light emitting diode (LED) at the bus stand.

II. METHODOLOGY

The process to develop this project is shown in Figure 1. It is started with the literature review process which worth being done to gain detail information and theories of the harvesting system development. Then, in the hardware development, it is divided into two parts namely mechanical development and circuit development respectively.

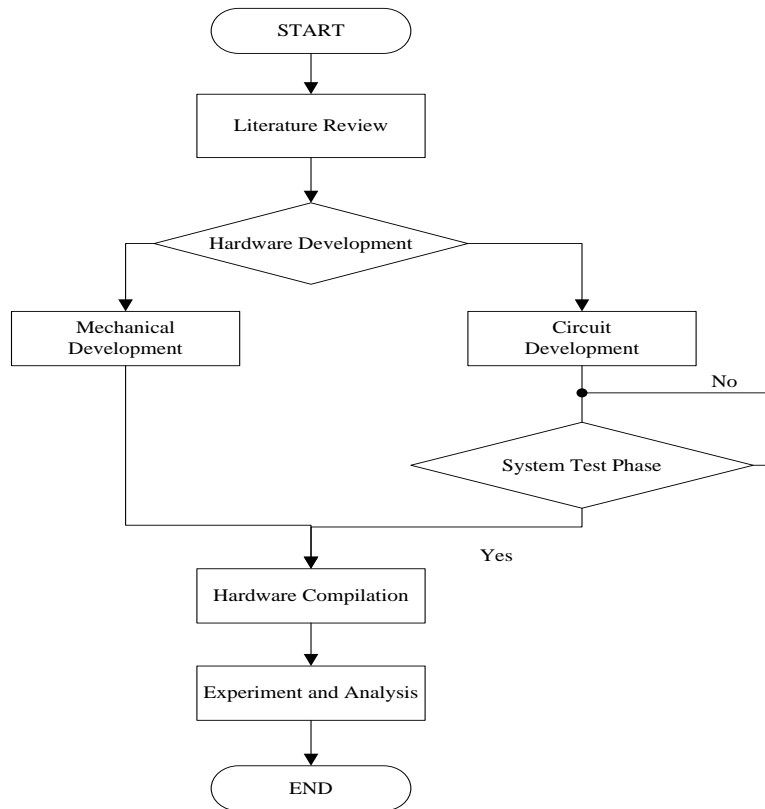

Figure 1 : The flowchart of project plan

In the circuit part, the rectifier circuit and storage circuit is designed using the MATLAB software and the output value is determined from the simulation. Figure 2 shows the full bridge rectifier circuit that is used to convert the output of piezo disc from AC to DC since its original output is AC.

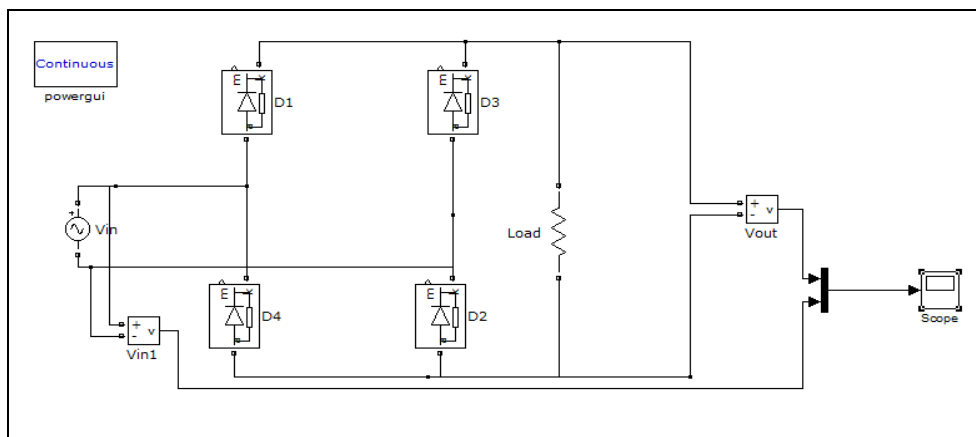

Figure 2 : Simulation circuit using MATLAB

After the circuit combined with all components such as piezo disk, super capacitor and load, the next step is to test the circuit to ensure that it meets the necessary requirements for the output specification. Meanwhile, in the mechanical development, the design of the model of bus stand and piezoelectric harvester base is carried out. The hardware is compiled then to determine the output of the piezoelectric energy harvester. The important part of this energy harvester is its base. This base development started by using solid work software before fabricate the real product. The rendered design using solid work software is shown in Figure 3. It has 81 small compartments that will hold the piezo disc. This base was design to make it portable and easy for setup.

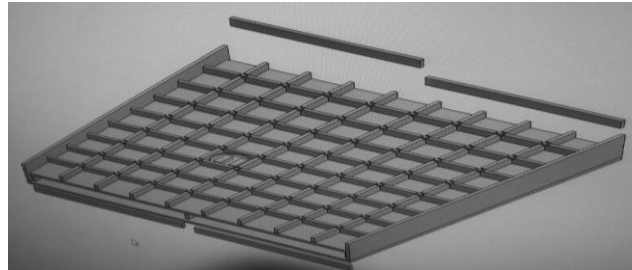

Figure 3 : Rendered design of piezoelectric harvester base

In general, by connecting piezo disc in parallel, the total voltage produced is maintained but current is increased. Vice versa, by connecting in series, total voltage is increased but current is maintained. For the piezoelectric energy harvester configuration in this project, piezo disc will be connected in parallel as shown in Figure 4 in order to maximize the produced output current. It is shown that artificial turf was placed on the top of the base to represent its green energy.



As stated before, after completing the design of the bus stand model and energy harvester base, the experiment was followed to determine the output voltage that can be generated from this model of piezoelectric energy harvesting system. The weight parameters to literally represent the people steps on the base of energy harvester is by using the dumbbell with three different weight values as shown in Figure 5(a). The output voltage is then recorded when the dumbbell weight is applied at the certain position on the base, as shown in Figure 5(b).



Figure 5: (a) Sizes of dumbbells that used in the experiment (b) Set up for the experiment

III. RESULTS & DISCUSSION

Two experiments were conducted to measure the output voltage, which the results will be presented in this section.

Experiment 1 (Output voltage at 4 cm height)

In this experiment, the dumbbell was released from the center, left and right of the base at the height of 4 cm to represent the footsteps of the people. Table 1 shows the complete results that have been recorded from the experiment.

Table 1 : Output voltage and current from piezoelectric harvester base

		Output voltage (V)			Output current (A)		
Weight	Position	center	left	right	center	left	right
	0.5		6.5	4.4	5.0	0.054	0.042
1.25		18.2	17.8	17.2	0.078	0.067	0.072
1.75		25.1	19.7	2039	0.114	0.092	0.114
2.5		28.4	21.4	22.2	0.134	0.124	0.136
3.0		30.4	29.3	28.4	0.205	0.193	0.251
3.75		36.2	33.6	34.2	0.372	0.272	0.297

As can be seen from Table 1, the maximum output voltage and current are 36.2V and 0.372A respectively when force was released at the centre of the base. From the weight of 0.5kg to 1.25kg, the output voltage at the center position increased dramatically from 6.5V to 18.2V. This was because of the piezo disc start to bend more which need to cover by a lot of piezo disc when receive a higher pressure. This validated the characteristic of piezoelectric material, which will produce higher voltage when more force applied to it. Therefore, it can be seen that, when weight of dumbbell was at 3.75kg, the output of energy harvester base was produced at highest reading compared when the weight of dumbbell was at 0.5kg. For the results of left side and right side of the base, the maximum output voltage and current were almost the same. The maximum output voltage and current are 33.6V and 0.272A for the left side of the base and 34.2V and 0.297A for the right side of the base, respectively.

The output from the center of the base was slightly higher compared to the output from the left and right side of the base. This is because when force was applied at the centre of the base, it will actuate and bend more piezo disc which leads to the higher force compared to the force applied at the left and right side. From this result, highest current that generated is recorded at 0.372A, which is sufficiently enough to charge the battery.

Experiment 2 (Output voltage at 8 cm height)

In this experiment, the procedure is repeated similarly with the previous experiment but this time the height of launching the dumbbell is selected at 8 cm. This height is to represent the footsteps from the people. The results that have been recorded were shown in Table 2.

Table 2 : Output voltage and current from piezoelectric harvester base

		Output voltage (V)			Output current (A)		
Weight	Position	center	left	right	center	left	right
	0.5		14.2	11.5	12.0	0.087	0.062
1.25		17.9	14.7	15.1	0.092	0.079	0.086
1.75		19.3	16.9	17.3	0.132	0.112	0.131
2.5		30.5	29.7	30.0	0.193	0.143	0.172
3.0		36.5	32.3	31.6	0.242	0.211	0.296
3.75		38.7	35.9	36.5	0.421	0.389	0.391

As can be seen from Table 2, when 0.5kg weight is applied to the center of the energy harvester base, the output voltages are 14.2V. This value is higher compared to 6.5V output voltage recorded at the same weight applied to the same center position from 4 cm height as shown in Table 1. This is because the two levels of height (4 cm

and 8 cm) will affect the output voltage and current produced. It can also be understood that the weight of the person stepping on the energy harvester will affect the output voltage and current produced. The result of output voltage and current when dumbbell was released at right and left position almost the same since the arrangement of piezo disc on left side and right side of the base are same. The maximum output voltage and current are 35.9V and 0.389A for the left side of the base and 36.5V and 0.391A for the right side of the base, respectively. In comparison, the output voltage and current when dumbbell was released at center are slightly higher compared to the output voltage and current when dumbbell was released at right and left position. This is because when there was a pressure in the middle of the base, many piezo discs affected and bended compared to the pressure applied at the left or right side of the base. Besides that, the weight of the dumbbell also affected the output of voltage and current that produced. From this result, highest current that generated is recorded at 0.421A, which is sufficiently enough to charge the battery.

IV. CONCLUSION & FURTHER RECOMMENDATION

In recent years, the idea of harvesting energy from clean energy has become increasingly popular. The ability of the system to use the ambient energy surrounding encourages the people to study more about piezoelectric effect. Piezoelectric materials have the ability to store the energy of the footsteps pressure and convert it to the electrical energy, which can be used in many electrical applications. By using high quality piezoelectric material such as bimorph element and polymer film, the output energy generated can be higher compared to the traditional piezo ceramic disc material. In conclusion, the concept of energy harvesting using piezoelectric material is presented in this paper. A prototype of piezoelectric energy harvester base was developed and the reliability of this system has been verified by conducting two different experiments. The verification parameters are the output voltage and the current produced by the energy harvester base. The objective to overcome the problem of lacking lighting system for bus stand at rural place is achieved and the wasted energy from people footsteps pressure can now be used efficiently as the source of electricity. The highest voltage and current recorded in this project is 38.7V and 0.421A, which is sufficiently enough to charge the battery.

VI. ACKNOWLEDGEMENTS

The authors would like to thank Universiti Teknikal Malaysia Melaka (UTeM) and Ministry of Education Malaysia for the financial supports given through Research Grant.

REFERENCES

- [1] R. Balma, And T. Kaya, "Battery-Free Energy Scavenging Applications And Power Conditioning Circuit" American Society For Engineering Education (Asee), March 2012.
- [2] Justin Scaparo And Dr. Tolga Kaya, "Piezoelectric Energy Harvester Design And Fabrication" Central Michigan University, Mount Pleasant, Mi 48859, 2012
- [3] François M. Guillot, Georgia Institute Of Technology, Me "Piezoelectric Fabrics For Energy Harvesting" National Textile Center Annual Report: November 2007
- [4] Daisuke Koyama And Kentaro Nakamura "Electric Power Generation Using A Vibration Of A Polyurea Piezoelectric Thin Film" Precision And Intelligence Laboratory Tokyo Institute Of Technology Yokohama, Japan, 2008
- [5] Brian Doyle "Piezoelectric Energy Harvesting" Material Science And Engineering, May 2012