

Feedback Controller for a 3-Phase 6-Pulse Rectifier

Sudeep Pyakuryal and Mohammad Matin

Daniel Felix Ritchie School of Engineering and Computer Science, University of Denver

-----ABSTRACT-----

In all phase controlled thyristor bridges, the dc output voltage is a function of supply line to line voltage and the phase angle of gate firing signal. In an ac to dc converter, it is desired to obtain a constant dc output voltage, in spite of disturbances. Some of the disturbances are due to change in supply voltage, supply frequency, or load current, and due to harmonics produced by converter itself. The values of circuit parameters are also within a certain tolerance. So in high-volume production of rectifiers, the rectifier output voltage lies in some distribution. It is desired to have the output voltage within a range. However, this is not practical to achieve the dc output voltage within the range without the use of a negative feedback controller. Thus, we cannot just set a fixed firing angle for thyristors and obtain a desired dc output voltage under all conditions. The idea behind the use of negative feedback controller is to design a circuit that automatically adjusts the firing angle to obtain desired dc output voltage regardless of the disturbances. In this paper a 3-phase 6-pulse rectifier is designed first with the independently running pulse generators and then a negative feedback integral control is applied to the rectifier. Alternative Transients Program, ATP, has been used to model the rectifier and negative feedback system, and to obtain thyristor firing signals, input voltage and current waveforms, and output voltage waveform.

KEYWORDS: Integral Control, Negative Feedback, Phase Control, Rectifier, Thyristor.

Date of Submission: 1August2013



Publication: Date 12August2013

I. INTRODUCTION

The medium-voltage high-power rectifiers find their use in various industrial plants. Their application are found for pipeline pumps in petrochemical industry, for steel rolling mills in metal industry, for pumps in water pumping stations, for fans in cement industry, for traction in locomotive industry, and in many other applications [1-8].

Fig 1.1 shows a general block diagram of a typical medium-voltage high-power drive [9].

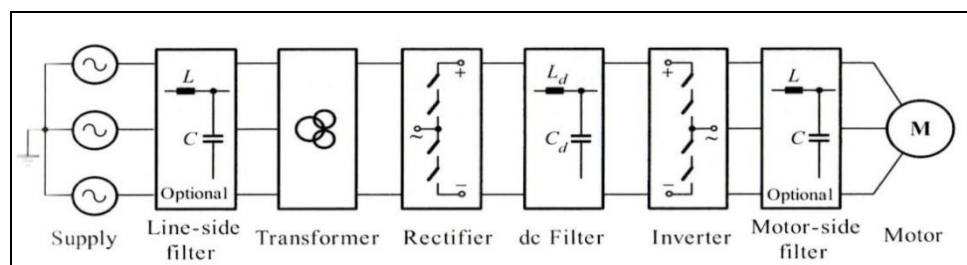

Figure 1. General block diagram of the MV drive

The input is 3-phase utility supply which is converted to dc voltage by the rectifier shown above. The dc voltage magnitude can be fixed or adjustable depending upon the power electronic switches that are used for switching. Multipulse silicon controlled rectifiers, SCR, multi-pulse diode rectifiers, or pulse-width-modulated (PWM) rectifiers are commonly used rectifier topologies.

In multipulse silicon controlled rectifier, SCR, or thyristor, the output dc voltage, V_d , is a function of input line to line voltage, V_{LL} , and the firing angle, α , of thyristor as given below [10]

$$V_d = 1.35 V_{LL} \cos \alpha \text{ ----- (1)}$$

Thyristor firing pulses can be generated from the independently running pulse generators. In practice, it is not possible to achieve an independently running firing circuit that precisely maintains the desired phase control of

firing pulses over the time. As time passes, the control angle either advances or retards gradually by increasing or decreasing the dc output voltage. In order to overcome this problem, a negative feedback integral control system can be used so that a closely regulated dc output voltage can be achieved and the output will not change gradually over the time. In negative feedback integral control system, the dc output voltage is compared with the desire voltage i.e. reference voltage and the error signal is processed to get firing angles such that a desired dc output voltage is obtained. In a negative feedback integral control system, the function of the firing pulse generator is to deliver correctly timed, properly shaped, firing pulses to the gates of the thyristors.

II. 3-PHASE 6-PULSE RECTIFIER

Fig 2 shows a simplified circuit diagram of a three-phase six-pulse thyristor rectifier. The inductance L_s is the total inductance including the line inductance, transformer reactance, and line reactor between the utility and the rectifier. For the ideal rectifier L_s is assumed to be zero. On the dc side a choke L_d is used to make the dc current ripple free [10-13]. The RC snubber circuits [14] for thyristor are not shown in Fig 2 but are considered in the computer model created in alternative transients program (ATP) [15].

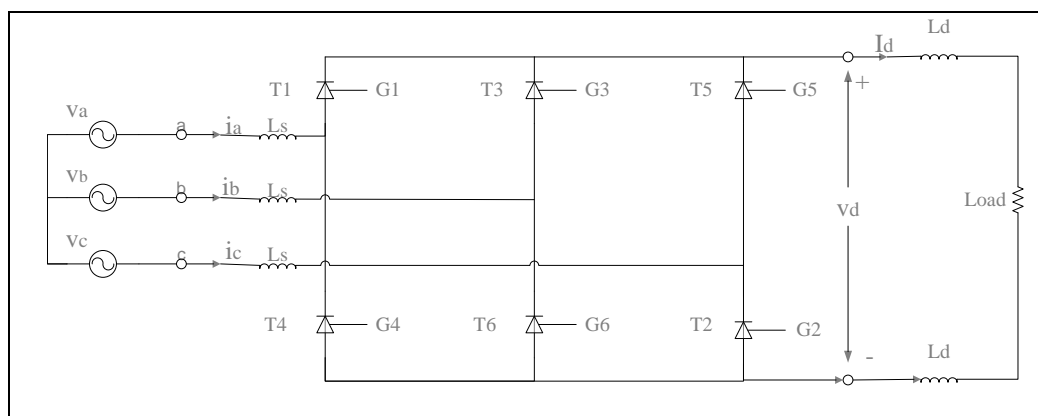

Figure 2. Simplified circuit diagram of a 3-phase 6-pulse thyristor rectifier

Fig 3 shows a typical dc output voltage of a 3-phase 6-pulse rectifier shown in Fig 2. The equation (1) in section I depicts that the rectifier dc output voltage V_d is positive when α is less than $\pi/2$ and becomes negative for α greater than $\pi/2$. The technique to control the dc output voltage by controlling the phase of firing pulse, α , is called phase-control technique [11].

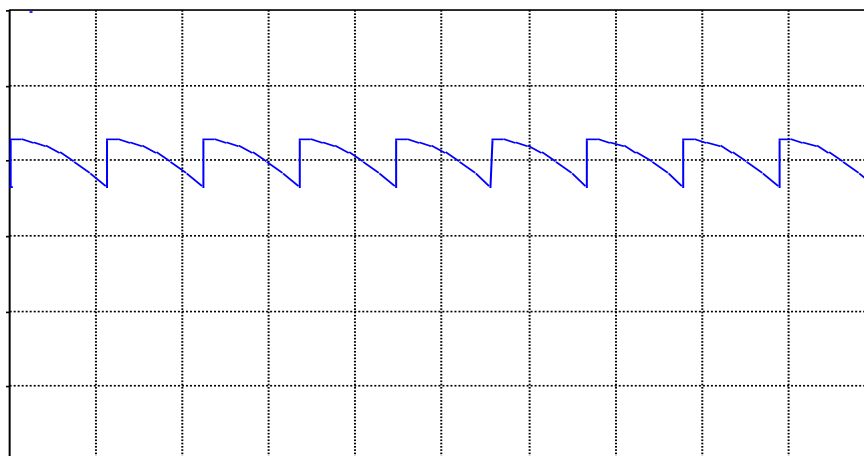

Figure 3. Typical dc output voltage with ac ripple

The power is delivered from utility to the load when the rectifier produces positive dc voltage. With a negative dc voltage, the rectifier operates as an inverter and the power is fed from the load back to utility. This often takes place during rapid deceleration when the kinetic energy of the rotor and its mechanical load is

converted to the electric energy by the converter working in inverter mode and are used for dynamic braking. But irrespective of the polarity of the dc output voltage, the dc current I_d is always positive.

III. NEGATIVE FEEDBACK CONTROLLER

There are two main types of feedback control system; a positive feedback system and a negative feedback system. In positive feedback system, the output variable and the control set point are added. In negative feedback system, the output variable is subtracted from the set point. The negative feedback system is more stable than positive feedback system [16]. In a negative feedback system, a Proportional Integral Derivative, PID, control is the most widely used control system in industry. In proportional branch, the error signal, the difference between the reference and the output, is multiplied by a constant. The proportional control is responsible for controlling the peak overshoot in the system. In integral branch, the error signal is integrated. The integral control is responsible for controlling steady-state error. In derivative branch, the error signal is differentiated. The derivative control is responsible for response time or settling time of the system. A negative feedback with integral control is presented in this paper to control the steady-state error in dc output voltage of a 3-phase 6-pulse rectifier by controlling the thyristor firing angle. Rectifier output voltage waveform and the waveform of integrator output is shown in Fig 4. The basic principle of the integral control method can be explained by the Fig 4.

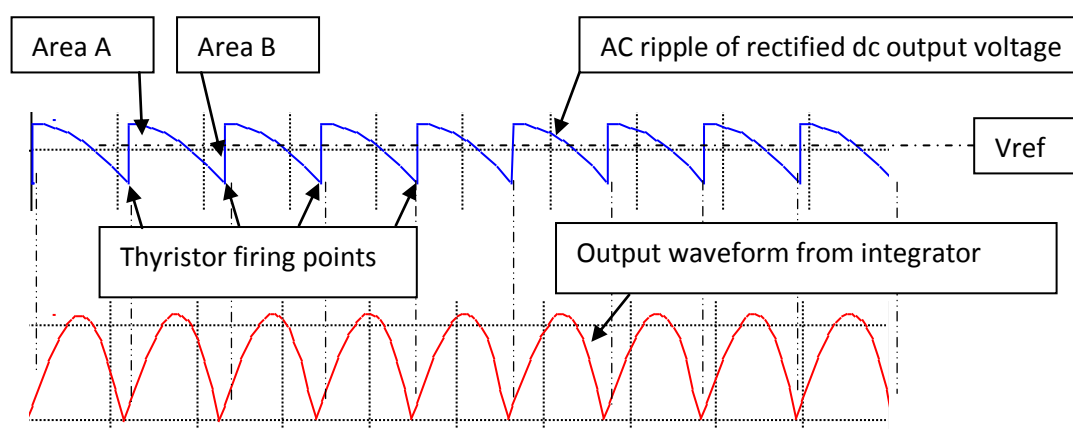

Figure 4. Basic Principle of the Integral Control

Examining the ac ripple of rectified output voltage, it is seen that during the interval between any two successive firing points, the net voltage-time integral of this wave is zero. In other words, area A, above the V_{ref} , and area B, below V_{ref} are equal. If the ac ripple is applied to the input of an integrator circuit, the output waveform of the integrator will be same as the one given in Fig 4. The output waveform from integrator shows that its value is zero at each firing point. Since the mean output voltage is equal to the reference voltage, the ac ripple waveform can be obtained by subtracting the reference voltage from the actual rectified output waveform. This scheme ensures that each and every segment of the output ripple voltage has zero mean value, and therefore between every two firing points the mean value of the output voltage is equal to reference voltage. Thus a very tight pulse by pulse control is obtained over the rectified output voltage waveform and in fact this principle automatically provides a closely regulated closed-loop control of the output voltage [17].

The integral control principle offers two important advantages. First, it is insensitive to changes in the supply frequency because the firing pulses are generated at the zero values of the integral of the ac ripple voltage. This means that, although the amplitude of the waveform of the integral of the error voltage changes with changing supply frequency, its zero values always correspond with the desired firing instants. Second, any spikes which appear on the output voltage waveform of the rectifier do not have any noticeable effect upon the timing of the firing pulses, since the integral value of the output ripple voltage is hardly influenced by these spikes. This is not the case with other types of pulse timing control, in which the timing of the firing pulses is determined from the instantaneous intersection of a timing waveform with the reference voltage [17]. A functional diagram of a 3-phase 6-pulse firing pulse generator using the integral control principle is shown in Fig. 5. The difference between the reference voltage and the rectified output voltage wave of the rectifier is fed as an input to the integrator. The output of the integrator is a replica of the output ripple voltage and therefore the output voltage of the integrator is the integral of the rectifier ripple voltage which has a zero-value at each firing point. This zero-value, by the action of a comparator, is translated into a timing clock pulse and the clock

pulse generator. The clock pulses are fed as the trigger input to a 6-stage firing pulse generator circuit. The function of the firing circuit is both to shape and distribute the output firing pulses. Each successive clock pulse produces a firing pulse in regular sequence, one after another [17].

IV. RESULTS

Fig 6 shows waveforms of the rectifier shown in Fig 2 with a negative feedback integral control, where v_a , v_b , and v_c are the input phase voltages of the utility supply, P1 thru P6 are the gate firing pulses for thyristors T1 thru T6 respectively and α is the firing angle of the thyristors. It should be noted that the number of thyristor and gate is also the sequence of their firing. The value of line to line voltage, V_{LL} , is 460 V_{ac} , firing angle of 30° , and from equation (1) the reference voltage is set at 538 V_{dc} .

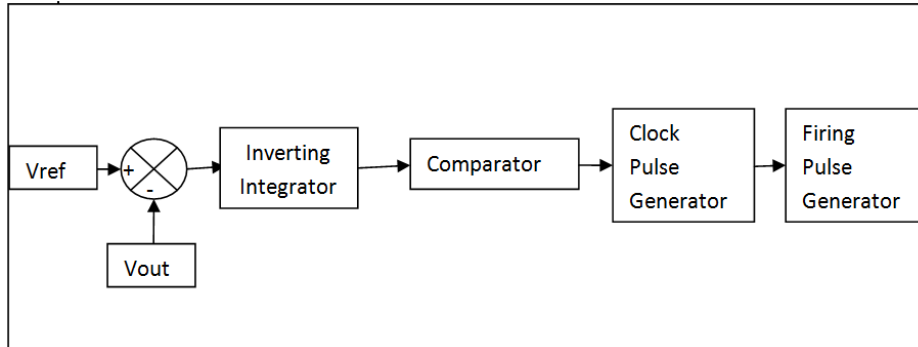

Figure 5. Integral Control Firing Pulse Generator

During interval I, thyristors T1 and T6 are conduct assuming T6 was conducting prior to turn on of T1. The positive dc voltage is v_p with respect to ground is v_a and the negative bus voltage v_n i.e. equal to v_b . The dc output voltage can be found from $v_d=v_p-v_n=v_{ab}$. The line currents can be given as $i_a=I_d$, $i_b=-I_d$, and $i_c=0$. During interval II, thyristor T6 is turned off after T2 turns on and the dc current I_d is commuted from T6 to T2. Thus T1 and T2 are conducting. The positive dc voltage v_p is still the same i.e. $v_p=v_a$ but the negative bus voltage v_n is equal to v_c . The dc output voltage can be found from $v_d=v_p-v_n=v_{ac}$. The line currents can be given as, $i_a=I_d$, $i_b=0$, and $i_c=-I_d$.

Following the same procedure all the voltage and current waveforms in other interval can be obtained.

V. CONCLUSION

A negative feedback control system with integral control principle is explained and applied to a 3-phase 6-pulse rectifier. The control system as well as the rectifier is modeled in ATP. The controller is designed to control the dc output voltage by adjusting the phase angle of thyristor firing signals. The generated firing pulses, the dc output voltage, as well as input current and voltage waveforms obtained from ATP are in agreement with the theory presented. Thus a successful implementation of negative feedback control system is achieved to control the steady-state error of a 3-phase 6-pulse rectifier by integral control method.

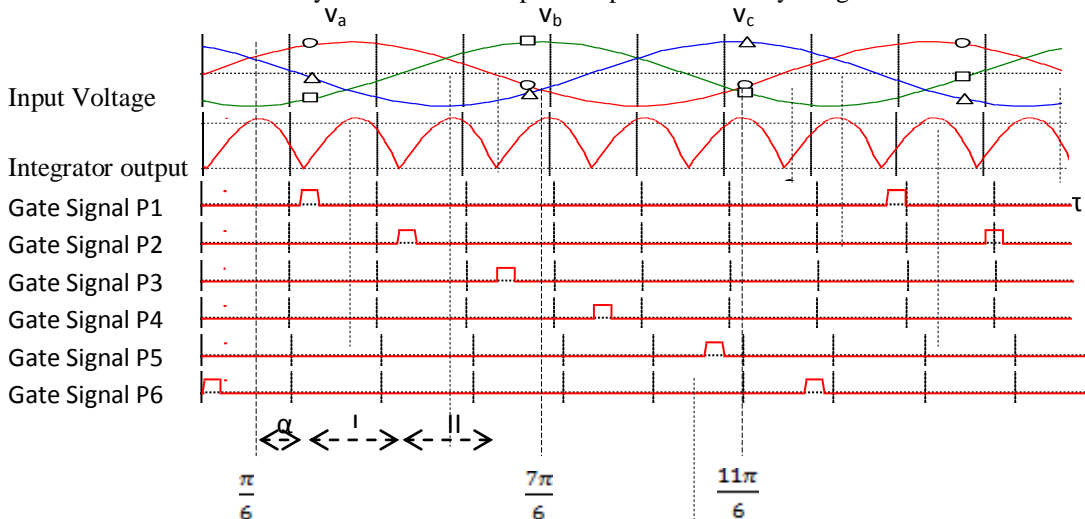

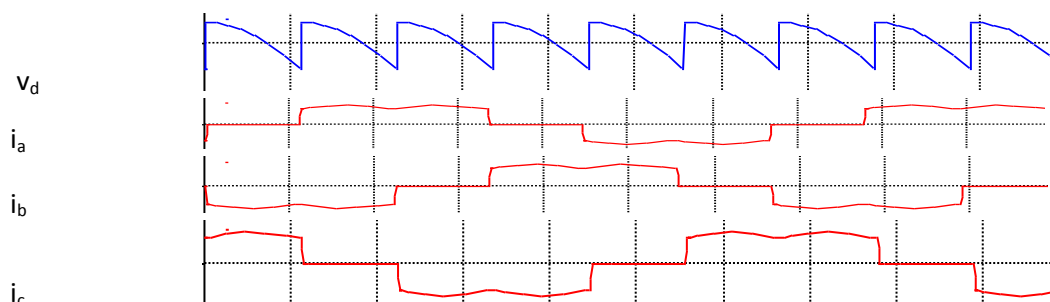

Figure 6. Waveform of an ideal six-pulse thyristor rectifier operating at $\alpha=30^\circ$

REFERENCES

- [1] R. Menz and F. Opprecht, "Replacement of a Wound Rotor Motor with an Adjustable Speed Drive for a 1400 kW Kiln Exhaust Gas Fan", The 44th IEEE IAS Cement Industry Technical Conference, pp. 85-93, 2002
- [2] W.C. Rossmann and R.G. Ellis, "Retrofit of 22 Pipeline Pumping Stations with 3000-hp Motors and Variable-Frequency Drives", IEEE Trans. on Industry Application, Vol. 34, Issue: 1, pp. 178-186, 1998.
- [3] N. Akagi, Large Static Converters for Industry and Utility Application, IEEE Proceedings, Vol. 89, No. 6, pp. 976-983, 2001.
- [4] N. Zargari and S. Rizzo, "Medium Voltage Drives in Industrial Applications, Technical Seminar", IEEE Toronto Section, 37 pages, November 2004
- [5] R.A. Hanna and S. Randall, "Medium Voltage Adjustable Speed Drive Retrofit of an Existing Eddy Current Clutch Extruder Application", IEEE Trans on Industry Applications, Vol. 33, No. 6, pp. 1750-1755.
- [6] S. Bernert, "Recent Development of High Power Converters for Industry and Traction Applications", IEEE Trans on Power Electronics, Vol. 15, No. 6, pp. 1102-1117, 2000
- [7] H. Okayama, M. Koyana, et al., "Large Capacity High Performance 3-level GTO Inverter System for Steel Main Rolling Mill Drives", IEEE Industry Application Society (IAS) Conference, pp. 174-179, 1996
- [8] B.P. Schmitt and R. Sommer, "Retrofit of Fixed Speed Induction Motors with Medium Voltage Drive Converters Using NPC Three-Level Inverter High-Voltage IGVT Based Topology", IEEE International Symposium on Industrial Electronics, pp. 746-751, 2001
- [9] B. Wu, High-Power Converters and AC Drives. IEEE Press 2006
- [10] S. Pyakuryal and M. Matin, "Harmonic Analysis for a 6-pulse Rectifier", IOSR Journal of Engineering, Vol. 3, Issue 3, pp. 57-60, March 2013.
- [11] S. Pyakuryal and M. Matin, "Implementation of AC to DC converter using Thyristor in ATP", IOSR Journal of Engineering, Vol. 2, Issue 11, pp. 6-11, Nov 2012.
- [12] S. Pyakuryal and M. Matin, "Ripple Control in AC to DC Converter", IOSR Journal of Engineering, Vol. 3, Issue 1, pp. 26-30, Feb 2013.
- [13] S. Pyakuryal and M. Matin, "Filter Design for AC to DC Converter", International Refereed Journal of Engineering and Science, Vol. 2, Issue 6, pp. 42-49, June 2013
- [14] A. M. Trzynadlowski, Introduction to Modern Power Electronics. New Jersey: John Wiley & Sons, Inc, 2010, Chap. 1.
- [15] ATP Rule Book at www.emtp.org accessed July 2013
- [16] I J Nagrath and M. Gopal, Control Systems Engineering, Anshan Ltd, 2008
- [17] B. R. Pelly, Thyristor Phase-Controlled Converters and Cycloconverters, Wiley-Interscience, 1971
- [18] N. Mohan, T. M. Undeland, and W. P. Robbins, Power Electronics-Converters, Applications, and Design. USA: John Wiley & Sons Inc, 1995
- [19] T. H. Barton, Rectifiers, Cycloconverters, and AC Controllers. New York: Oxford University Press, 1994
- [20] B. K. Bose, Power Electronics and Variable Frequency Drives-Technology and Application. New Jersey: IEEE Press, 1997
- [21] R.W. Erickson and D. Maksimovic, Fundamental of Power Electronics, Springer, 2001